



NOTE

You can prevent unauthorised persons from using your ergo_bike pedelec by entering a lock code.

In order to create your own lock code (**1 to 8 digits numeric code**) you need first the **"always valid" master lock code** for your bike.

If you forget your own lock code, enter instead of it the "always valid" master lock code for your bike.

Therefore you should store this code in a safe place!

The IMEI (International Mobile Station Equipment Identity) is an univoque 15-digit serial number with which each GSM device can be unequivocally identified - e.g. in case of theft.

classic model

For the serial number of your frame: _____

the "always valid" master lock code: _____

premium model

For the serial number of your frame: _____

the "always valid" master lock code: _____

IMEI serial number: _____

We develop and manufacture also training devices for sport, therapeutic and medical usage. More than 500,000 devices are in use by satisfied customers around the world. Visit our web page at www.daum-electronic.de to learn more about our complete product range.



Your daum electronic dealer

daum electronic gmbh
Flugplatzstr. 100 · D-90768 Fürth
Telefon: +49 (0)911 97536-0 · Fax: +49 (0)911 753714
www.daum-electronic.de

no. 0630424e.0002

2010 03 001



User Manual

ergo_bike pedelec

*classic
premium*



Pedelec stands for Pedal Electric Cycling

It designates a bike with electric assisted pedalling having the following characteristics:

- Pedelecs combine a bike with an electric motor, a rechargeable battery, control electronics, and sensors for recognising crank movements.
- Pedelecs are considered as bikes and may be used without driving licence and without automobile liability insurance.
- A helmet is not required but we do recommend wearing a bicycle helmet.
- All pedelecs sold in the EU must comply with the directive DIN EN 15194.
- While pedalling pedelecs are assisted by a motor from 0 to 25 km/h.

We recommend that you carefully read this user manual to quickly familiarise yourself with your ergo_bike pedelec. Competent handling and regular care and maintenance of the ergo_bike pedelec help preserve its value.

Also for safety reasons take into consideration the information about modifications, accessories, and spare parts.

Please if you sell your ergo_bike pedelec

give also this user manual to the buyer.

daum electronic is permanently working to improve all its models. Keep in mind that the delivery scope can be modified any time. The modifications can cover the form, equipment, and technology. Therefore no complaint or claim can be made based on the illustrations and descriptions contained in this user manual.

All texts, illustrations, and instructions contained in this user manual are actual at the moment this user manual is put to print. The data contained in this user manual are valid at the moment of printing. Errors and omissions excepted.

The illustrations show the Comfort model for the extend that it does not differ from the Trekking model. The descriptions for the Trekking D (ladies) and Trekking H (gentlemen) models are similar.

Reprinting, copying, or translating of this manual, in complete or in parts, is not allowed without an express authorisation. All the rights remain with daum electronic according to the Copyright law. Subject to modifications.

daum electronic gmbh

Used symbols

Notes important to your safety are especially identified. Take these notes into consideration to avoid injuries to a person and damages to the bicycle.



WARNING

Warns you against hazards for your health and indicates potential injury risks.



ATTENTION

Signals possible dangers for the bicycle or other objects. Non-observance of these remarks can lead to voiding the warranty.



NOTES

Highlight tips and information for you.

The keys

Two identical keys for the battery are provided with your ergo_bike pedelec. Please keep the spare key in a safe place.

Please read all the important information about the SHIMANO gear shift, the suspended fork, and the TRANZ X in the included manufacturer's manual.

OPERATING classic and premium

Side view of the right side 2
 Handlebar functions and operation 3
 Seating position 4
 Adjusting the saddle 4-5
 Adjusting the handlebar 6-7
 Adjusting the suspension fork 8
 Safety hints for the battery charger 9
 Battery charger operations 10
 Safety hints for the rechargeable battery .. 11
 Handling the rechargeable battery 12
 and the charger
 Charging the rechargeable battery 13-15
 Dashboard 16
 Menu diagram 17
 Displays 18-21
 SD card 22-23
 Software update 23-26

OPERATING premium series

Functions overview 27
 GSM/GPRS 28-29
 Displaying travelled tracks
 with Google Earth 30-31
 Displaying travelled tracks with GPSies .. 32-33
 Posting your own tracks on Internet 33
 GPS menu 34

Biking through tracks from Internet 35-38
 Your own tracks / last tracks 39
 Querying the position 39
 Sending the position 39
 Determining the altitude 39-40

BIKING

Starting up 41
 Assistance level 42
 Pushing assistance 42-43
 Driving conditions 43
 Hub gear 44
 Recommends 44
 Braking 45
 Parking 46
 Safety hints 47-49
 Transport 50
 Theft protection 50
 Carrying loads 50

CARE

Bicycle care 51-52
 Disposal of waste 53
 Technical modifications, spare parts 54

ACCESSORIES..... 54-55

MAINTENANCE AND CARE

Miscellaneous 56
 Maintenance and care plan 57-58
 Bike chain tension 59
 Verifying chain wear 60
 Pedal cranks, pedals 61
 Steering bearing, spokes 62
 Adjusting the brakes 63-65
 Disassembling and assembling
 the front wheel 66-67
 Disassembling and assembling
 the rear wheel 68-69
 Hub gear 69
 Dismounting and mounting the tyres ... 70
 Lighting system 71
 Checking the fuse of the rechargeable
 battery and of the charger 72

SPECIFICATIONS 73-77

WARRANTY AND SERVICE

Warranty conditions 78
 Wear parts list 79-80
 Delivery list 81

EC DECLARATION OF CONFORMITY 82

BIKE ID CARD 83

Side view of the right side

- 1 Display
- 2 Handlebar
- 3 Handlebar stem
- 4 Serial number
- 5 Saddle clamp for saddle height
- 6 Rechargeable battery, lockable
- 7 V-Brake rear wheel
- 8 Side stand
- 9 Electric motor
- 10 Pedals
- 11 Hub dynamo
- 12 Quick release lever front wheel
- 13 V-Brake front wheel

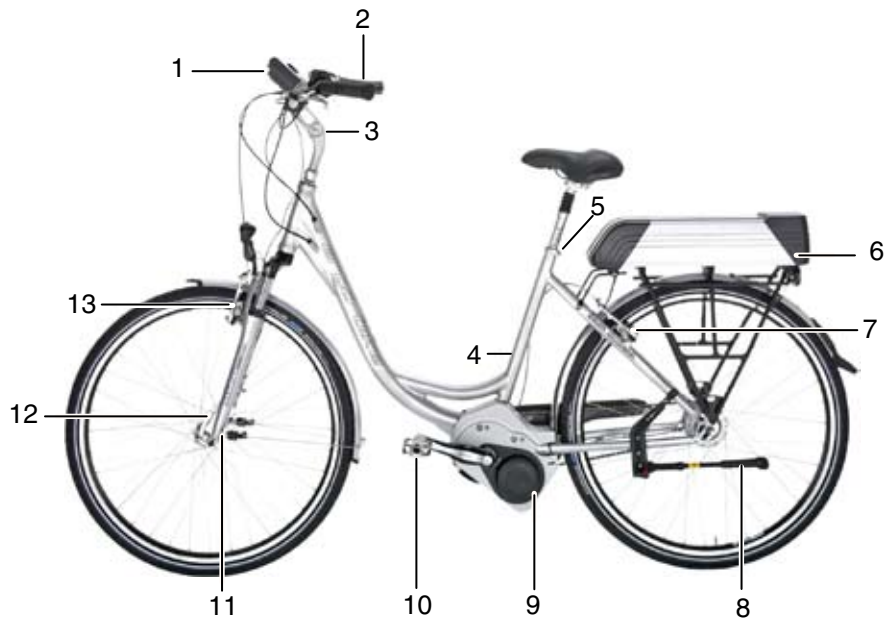

Handlebar functions and operation

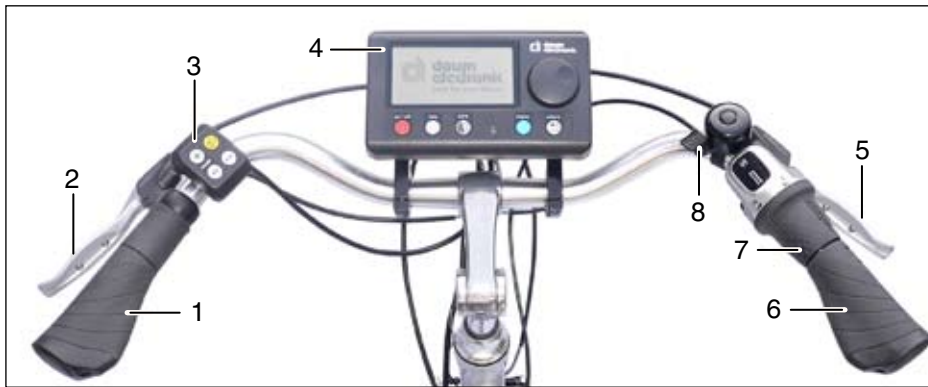

- 1 Handle
- 2 Brake lever for the front wheel
- 3 Close control buttons
- 4 Dashboard with display

- 5 Brake lever for the rear wheel
- 6 Handle
- 7 8-speed twist gear shifter
 - + : 1 x shift to the next higher speed
(8th speed = highest transmission ratio)
 - : 1 x shift to the next lower speed
(1st speed = lowest transmission ratio)
- 8 Bell

Close control buttons

- 1 Decrease assistance level
- 2 Increase assistance level
- 3 Pushing assistance
- 4 Switching the display between standard view and:
 - "Current data" (only with premium model)
 - "Current tour"
 - "Total values"
 - "GPS data" (only with premium model)

Seating position

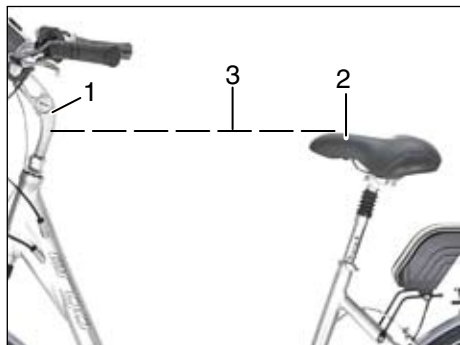

Adjust the height of the saddle and handlebar to adapt them to your body size in order to allow for a comfortable, non tiring, and safe driving.

Sit on the saddle, put one pedal in the lowest position and place your heel on the pedal. The saddle height should be set so that your leg is almost straight in the lowest pedal position.

The handlebar setting is correct when the handlebar stem (1) is at the same level (3), or a little higher as the upper edge (2) of the saddle.

Setting the saddle height



WARNING

Please note that the saddle may be pulled up at most to the marking (2) on the saddle tube.

- Loosen the saddle clamp (1) by means of an Allen wrench SW4, adjust the saddle height and retighten the screw.

Adjusting the saddle



The saddle can also be inclined and adjusted in the longitudinal direction.

- Loosen screw (1).
- Position the saddle in the required horizontal position or shift it to the front or to the rear and tighten screw (1).



NOTE

To avoid sitting discomfort, the saddle should be set as horizontal as possible.

Setting the spring suspension of the saddle pillar

The saddle pillar (2) equipped with a spring suspension can be set to be soft or hard.

The setting is done by means of an Allen wrench SW6 on the lower end of the saddle pillar.

- To this end loosen the clamp (3) of the saddle pillar and pull out the saddle.
Turn clockwise = harder
Turn counterclockwise = softer
- Insert the saddle pillar, adjust the saddle height, and tighten the clamp (3) of the saddle pillar.

Adjusting the handlebar height on the Comfort model

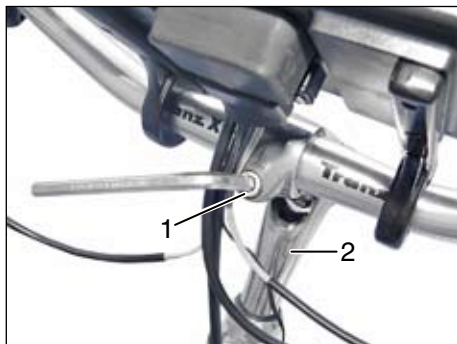

- Loosen the clampscrew (1) of the handlebar stem (2) using an Allen wrench SW6.

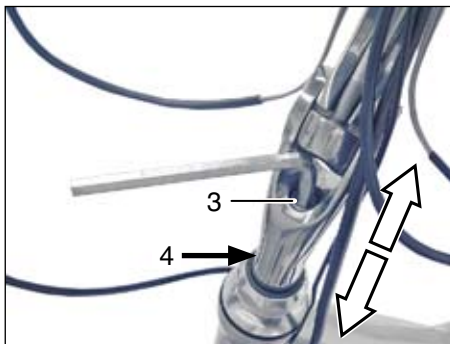

- Loosen the clamp screw (3) of the handlebar stem using an Allen wrench SW6 by one to two turns.



NOTE

The clamping is done by a conical body. It is therefore enough to apply a rotary motion to the handlebar to loosen the clamping.

- Adjust the handlebar height and tighten the clamp screw (3).



WARNING

Please note that the handlebar stem may be pulled up at most to the marking (4).

Adjusting the handlebar position on the Comfort model

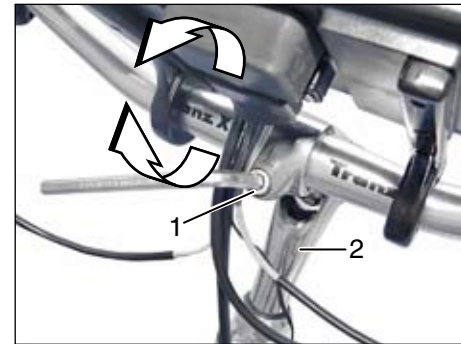

- Loosen the clamp screw (1) by means of an Allen wrench SW6.
- Adjust the handlebar position by moving the handlebar stem (2).
- Tighten the clamp screw (1).



NOTE

Pay attention to leave the sheathed cables free running and avoid setting the handlebar to the extreme high or low position.

Adjusting the handlebar stem on the Trekking model



- Loosen the clamp screw (1) of the handlebar stem (2) by means of an Allen wrench SW6 and adjust the position.
- Retighten the clamp screw (1).

Adjusting the handlebar position on the Trekking model

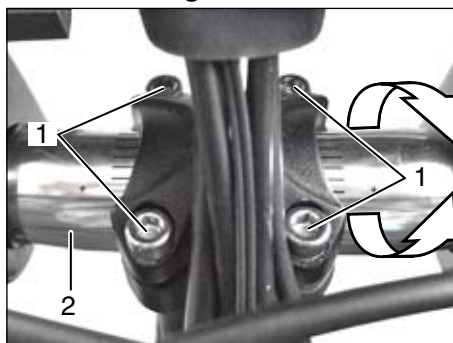

- Loosen the four clamp screws (1) by means of an Allen wrench SW6.
- Adjust the handlebar position by shifting the handlebar (2).
- Retighten the clamp screws (1) alternately crossed.



NOTE

Pay attention to leave the sheathed cables free running and avoid setting the handlebar to the extreme high or low position.

Adjusting the suspension fork

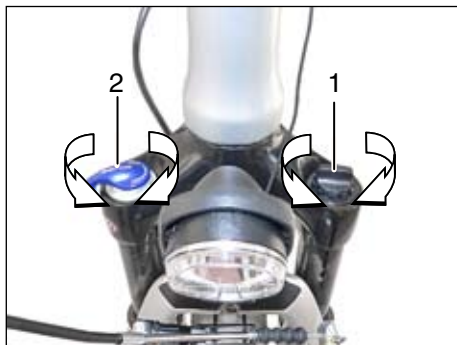

Adjusting the initial tension of the suspension fork



NOTE

The initial tension is used to adjust the response characteristics of the suspension fork to adapt it to the road conditions and user's weight. The higher the initial tension is, the higher the pressure to apply before the suspension fork reacts.

Turn the setscrew (1) as desired:

+ = Suspension hard:

Turn clockwise to increase the initial tension.

- = Suspension soft:

Turn counterclockwise to decrease the initial tension.

Lock function (option)

If required you can lock the suspension of the fork by means of the lock lever (2).

LOCK = suspension locked

OPEN = suspension active



WARNING

Do not make any other modification to the suspension fork.

Important safety notes for the battery charger

Please read these safety notes before you start using the battery charger.

WARNING

Keep the charger out of reach of children. To prevent risks of injury you should only recharge daum electronic Lithium-Ion (Li-Ion) rechargeable batteries. Other battery types may explode when recharged. This can cause injuries to persons and material damages.

Using accessories or rechargeable batteries that we do not sell or recommend, introduces risks of fire, electrical shocks or injuries.

In any case avoid using the device in humid or wet environment.

Avoid absolutely water infiltrations in the device. If liquid infiltration does occur: immediately disconnect the charger from the power supply and take it to your daum electronic dealer for testing.

Please provide for a safe stand for the device on a flat level surface.

When not in use disconnect the power supply.

Do not pull on the cable to avoid damaging the cable and prevent the risks of an electrical shock.

After use, make sure that the power cable is properly rolled up or fold up.

Do not use the charger with a damaged cable or power plug. Have it immediately replaced by a qualified technician.

Do not use the charger after it received a strong shock, was dropped or anyhow damaged.

Do never disassemble the charger yourself. A faulty assembly can lead to electrical shocks or fire hazards.

To prevent electrical shocks, disconnect the charger from power supply before cleaning it.

Clean the device only with a dry cloth. Do never use oil, water or solvents.

An extension cable should only be used if absolutely necessary. Using an extension cable that is not in perfect condition can lead to fire hazards or electrical shocks. If an extension cable is used, you must make sure that:

- the pins of the cable power plug correspond to those of the charger exactly in number, size and shape,
- the extension cable is correctly wired and in good electrical state,
- the cable section is large enough to support the AC current load of the charger,
- the extension cable does not present any visible damage,
- the drum is completely unwound when when using cable drums.

Battery charger operations

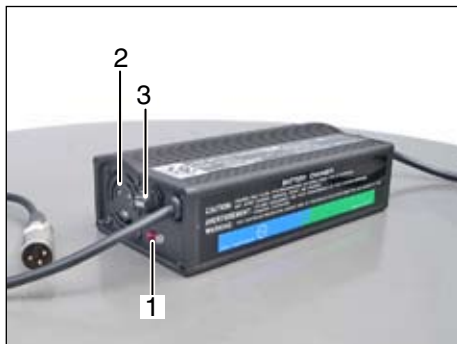

The LEDs (1) on the battery charger give actual information about the operation of the battery charger. You can check at a glance the charging status and charging state of the rechargeable battery.

Charging cycle and LED displays on the charger

LED	Mode
Red and yellow	Charging
Red and green	Charging completed



ATTENTION

To prevent overheating the charger, the ventilator (2) may not be covered during the charging process.

In case of troubles check if:

- the fuse (3) of the charger is defective?
- the power cable is properly plugged in?
- the contact pins of the charger and the rechargeable battery are clean and not damaged or bent?
- the rechargeable battery is damaged or defective?
- the plug of the charger is firmly plugged in the connector of the rechargeable battery?

In the case that a proper battery charge cannot be obtained:

- Verify that the power outlet is connected to power, eventually plug in another device.
- Verify that the connecting plugs fit in properly and establish contact.
- If it is still not possible to recharge the battery, then please have the charger and the rechargeable battery tested by your daum electronic dealer.

Important safety hints for the rechargeable battery



Before starting operating, we strongly recommend you read the following important notes and comply with them:

- A new ergo_bike pedelec rechargeable battery is charged to about 80% capacity.
- The rechargeable battery develops its maximum capacity after about five discharge/recharge cycles.



WARNING

- **The rechargeable batteries of the ergo_bike pedelec and the provided charger are tuned to each other. Therefore you should always recharge the battery with a charger of the same model series.**

- Protect the rechargeable battery against shocks and humidity.
- Before you plug the charger into a power outlet please verify that the voltage supplied corresponds to the voltage specified on the nameplate of the charger.
- Rechargeable batteries will achieve their maximal usable life when recharged in an ambient temperature of +10°C to a max. of +30°C.
- The rechargeable battery will get warm when used heavily. Please wait for the rechargeable battery to cool down to room temperature, or about 30 minutes, before starting the recharging process.



WARNING

- **Keep the rechargeable battery out of reach of children.**
- **Do not open or disassemble the rechargeable battery yourself.**
- **Do not short-circuit the rechargeable battery with metal objects.**
- **Do not immerse the rechargeable battery in any liquid.**
- **A not usable rechargeable battery may not in any case be incinerated or put to fire! There is risk of explosion!**



CORROSION RISK

- **Stop using the rechargeable battery in the presence of leaks or loss of electrolyte.**



FIRST AID

Rinse acid sprays in the eyes immediately with clear water for a few minutes! Then consult a physician without delay.

Neutralize acid splash on skin or clothes immediately with acid neutralizer (soda) or soap suds and rinse with plenty of water.

If acid is swallowed (drank), consult a physician immediately.



NOTE

Used rechargeable batteries are subject to waste disposal regulations. Rechargeable batteries contain heavy metals and are therefore subject to toxic (hazardous) waste control.

Your daum electronic dealer will take care of battery disposal for you.

Handling the rechargeable battery and the charger



ATTENTION

Ignoring the following directives can lead to a deep discharge of the rechargeable battery.

A deep discharge of the rechargeable battery voids the warranty.

In order to achieve the longest possible service life of the rechargeable battery you should follow the following directives:

- The charger will not operate when the temperature of the rechargeable battery is below 0°C and higher than

+60°C. Therefore you should bring the rechargeable battery to about room temperature before starting the charging process.

- If the pedelec will be exposed to low temperatures at its storage location, we recommend to remove the rechargeable battery and store it at room temperature.
- If the rechargeable battery is kept turned off or removed for an extended period of time, then it is expected that you will need to set the date and time again!
- Recharge the battery at the soonest opportunity after use, regardless of the amount of discharged energy.
- After the charging process is complete, the rechargeable battery must be disconnected from the charger, and it may not be left connected to a switched off charger (self discharge).

- When not used for a prolonged period, the rechargeable battery may not be left connected to the charger.
- When storing the bike (e.g. in winter) the rechargeable battery must be stored fully charged in a dry room at room temperature.
- Recharge every 3 months.



NOTE

About self discharge

The rechargeable battery will self discharge mainly through chemical processes occurring in the gas-tight cells. The discharge rate depends on the time, charging level and environmental conditions (temperature, air humidity).

This results in a correspondingly shorter range with electric drive.

Removing the rechargeable battery to recharge it

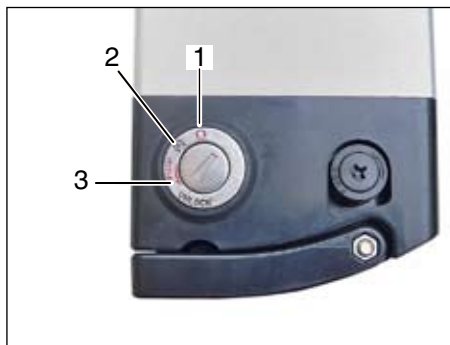
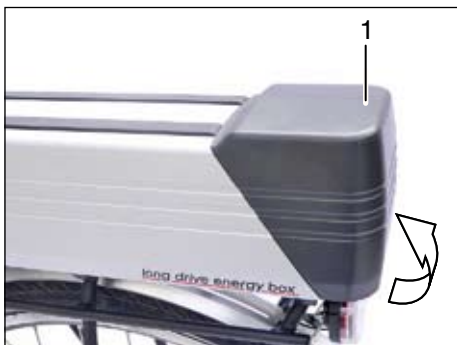



NOTE

The rechargeable battery is locked by means of a key-lock. The rechargeable battery must be removed from the battery compartment to be recharged.

The charging time is about 3 hours for a discharged rechargeable battery.

- Open the cover (1) of the battery compartment upward.

Key positions on the rechargeable battery

- 1  Operating position: the rechargeable battery is switched ON.
- 2  The rechargeable battery is switched OFF. The key can be removed.
- 3 **PUSH** The rechargeable battery is unlocked **UNLOCK** and can be removed.



- Press the key (4) and turn it counter-clockwise to the **PUSH UNLOCK** position. The rechargeable battery is unlocked.

- Pull the rechargeable battery on the handle (5) out of the battery compartment.

Charging the rechargeable battery

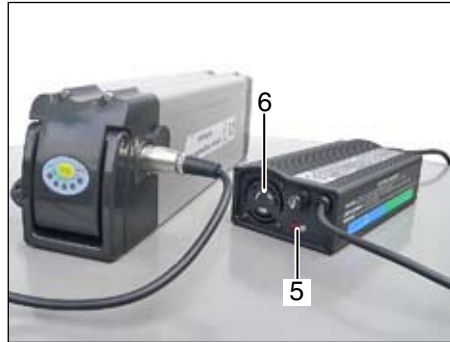
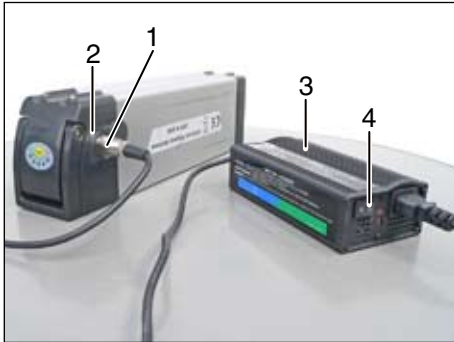

ATTENTION

The switch (4) on the charger may only be switched ON after the connections to the rechargeable battery and to the power supply have been established. Otherwise the charging process will not start.

After the charging process is complete disconnect the rechargeable battery from the charger.

- Connect the plug (1) to the connector (2) of the rechargeable battery.
- Connect the power plug of the charger (3) to a power outlet at 100-240V, 50-60Hz.
- Turn ON the switch (4) on the charger.

Charge status on the charger

The LEDs (5) on the charger indicate the charging status.

Red + yellow The charging process is active and the ventilator (6) is running.

Red + green The charging process is complete and the ventilator is not running.

Checking the charge level of the rechargeable battery

- The LEDs (7) (red + green) light up when you press the ON key (8).

When the rechargeable battery is fully charged all 4 green LEDs and the red one will glow.

Installing the rechargeable battery

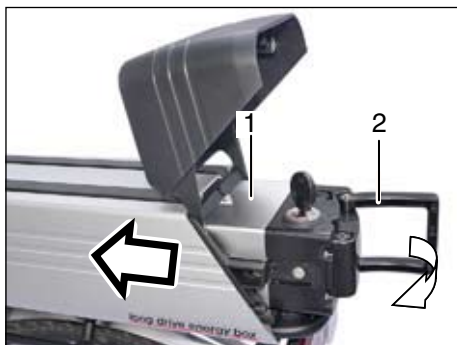

- Insert the rechargeable battery (1) in the battery compartment until it stops and fold the handle (2) back.



- Turn the key (3) to the right into position . This will lock the rechargeable battery and turn it OFF.



ATTENTION

- The rechargeable battery must be turned OFF when not in use.

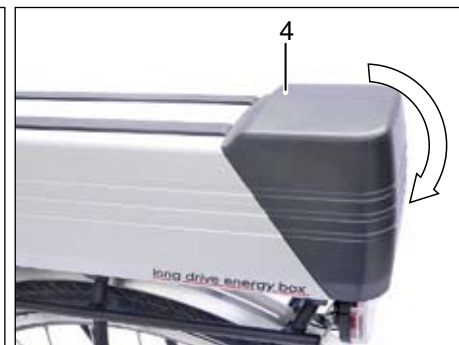

- Close the cover (4) of the battery compartment.

Dashboard functions and operation

1 Display

- 1.1 Speed in km/h
- 1.2 Assistance level / Energy consumption / Pushing assistance
- off (without motor assistance)
 - low (with motor assistance)
 - normal (with motor assistance)
 - high (with motor assistance)
- Energy consumption (length of the bar)
- Pushing assistance (up to 6 km/h)

1.3 Energy

- Rechargeable battery charge level % (length of the bar)
- Remaining travel range in km based on the energy consumption for the current tour and the last 5 minutes

1.4 Time / Trip time

1.5 Tour kilometre

1.6 Heart rate (option)

Measuring range of the heart rate 40 to 220 (The menu option to set the displayed value is available only on bikes of the premium series)

1.7 GPS position

(only on bikes of the premium series)



- | | |
|--|---|
| 2 Control button (turn and press)
Main menu - sub menus | 5 Menu ON/OFF key |
| 3 Return key
Sub menu - main menu - normal display | 6 Display brightness sensor |
| 4 SD card slot | 7 GPS key (only on bikes of the premium series) |
| | 8 Info key |
| | 9 ON/OFF key dashboard and motor |

Menu diagram overview ergo_bike pedelec

Bold text on clear background:
only for bikes of the premium series

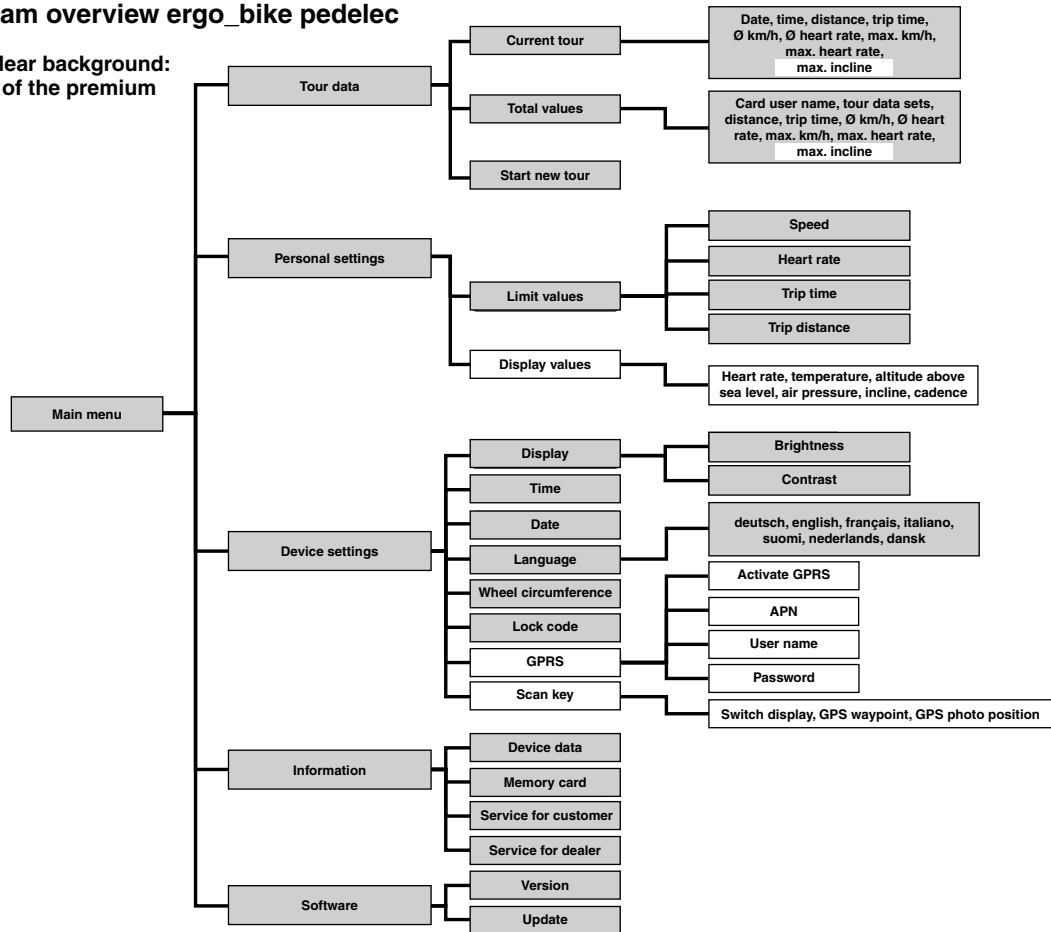

Displays



Using the menus

The menu is activated by pressing the menu key (1).

Turn the control button (2) to navigate in the menu.

Press the control button (2) to open a sub menu.

Press the return key (3) to return to the previous menu.

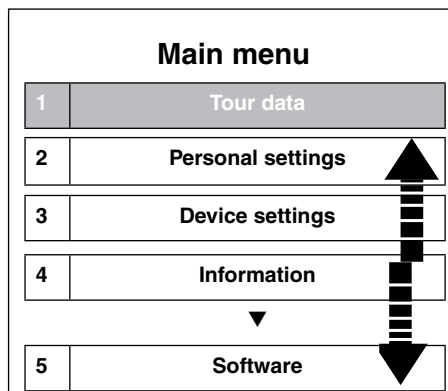

Turn the control button (2) on the dashboard to navigate to the menu options 1 to 5.

Press the control button to open the sub menus.

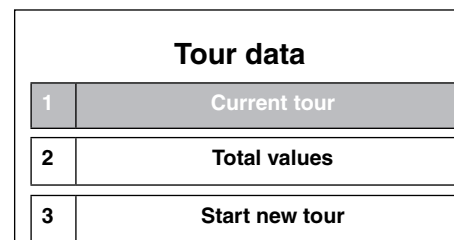

1 Current tour
Date, time, distance, trip time, Ø km/h, Ø heart rate, max. km/h, max. heart rate, max. incline (premium series)

2 Total values
Card user name, tour data sets, distance, trip time, Ø km/h, Ø heart rate, max. km/h, max. heart rate, max. incline (premium series)

Turn the control button to switch between the display modes.

3 Start new tour
Current tour counter is reset to 0.



NOTE

That also happens

- after a trip pause of at least 6 hours,
- when the tour length of 24.5 hours is exceeded.

Displays

Main menu	
1	Tour data
2	Personal settings
3	Device settings
4	Information
▼	

Personal settings

1 Limit values

- Set the speed at which motor assistance should cease (max. 25 km/h). When the actual speed exceeds the limit value the speed display will blink.
- Heart rate; set the limit value. When the actual value exceeds the limit value an audio signal sounds and the heart rate display blinks.
- Set the trip time in minutes. When the actual trip time exceeds the limit value an audio signal sounds and the trip time display blinks.
- Set the trip distance you want to ride in km. When the actual distance exceeds the limit value an audio signal sounds, and the distance display blinks.

Personal settings	
1	Limit values
2	Display values

2 Display values

The display values can be set only on bikes of the premium series (see page 16 / 1.6).

Display 1	
Heart rate	▲
Temperature	■
Altitude above sea level	
Air pressure	
Incline	▼
Cadence	

Main menu	
1	Tour data
2	Personal settings
3	Device settings
4	Information
▼	

Device settings

- 1 Display** Brightness – Contrast
- Time (important for the recording of tour data on the memory card)
- Date (important for the recording of tour data on the memory card)
- Language
- Wheel circumference
The wheel circumference is set at the factory to 216 cm as a reference value. This menu permits to correct this value according to total weight, tyre air pressure, and tyre type.
- Lock code
- GPRS (only on bikes of the premium series, see page 29)
- Scan key (only on bikes of the premium series, set the function of the scan key: "Switch display", "GPS waypoint" or "GPS photo position").

Displays

Display lock code



NOTE

You can prevent unauthorised persons from using your ergo_bike pedelec by entering a lock code.

In order to create your own lock code (**1 to 8 digits numeric code**) you need first the "**always valid**" **master lock code** for your bike.

If you forget your own lock code, enter instead of it the "always valid" master lock code for your bike.

Therefore you should store this code in a safe place!

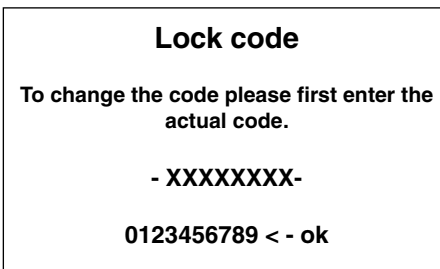

NOTE

As delivered no personal lock code is created.

In order to set your personal code you must enter first the master lock code set at the factory. The master lock code is located on the last inner page of this user manual.

Enter the actual master lock code by turning and pressing the control button.

Press the control button for every digit entered. An X will be displayed in the upper line for every digit.

When the code is entered turn to select OK and press the control button.



Lock

Enter your personal lock code of 1 to 8 digits by turning and pressing the control button.

Press the control button for every digit entered. An X will be displayed in the upper line for every digit.

When the code is entered turn to select OK and press the control button.

Your display can now be activated only with your personal code.



NOTE

If you want to deactivate the lock code, set a new lock code, turn the control button directly to OK and press the control button.

Displays

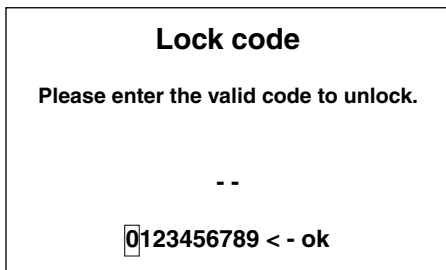

Unlock

Enter your personal lock code upon switching ON the display.

Press the control button for every digit entered. An X will be displayed in the upper line for every digit.

When the code is entered turn to select OK and press the control button. The display is activated.



NOTE

If you forget your own lock code, enter instead of it the master lock code for your bike as the actual code.

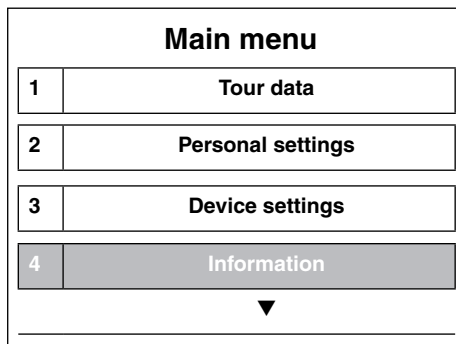

Information

- 1 Device data
- 2 Memory card
- 3 Service for customer
- 4 Service for dealer

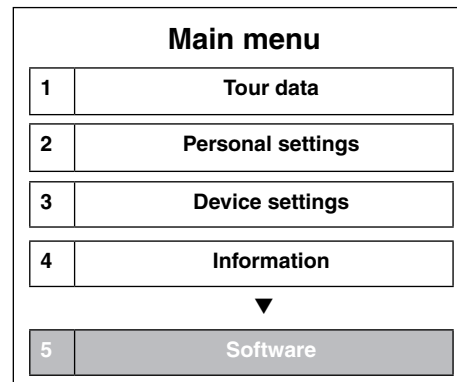

Software

- 1 Version
- 2 Update

SD card

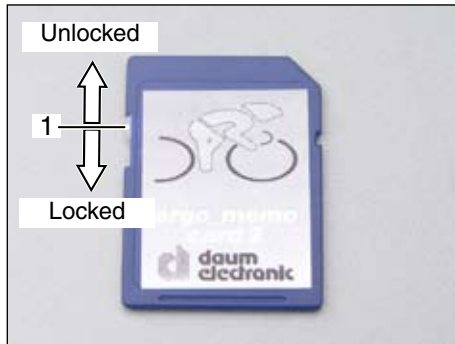

The slider (1) of the ergo_memo-card2 must point upward when the card is inserted into the dashboard. This enables writing to the card.

When the slider (1) is pointing downward the card is locked and write protected.

What to consider when manipulating memory cards?

1. Electrostatic discharges can damage electronic components. Therefore discharge your body of any potential electrostatic charge before manipulating the memory card, by touching a grounded metallic object (e.g. heating or water pipe).

2. Avoid always touching the uncovered gold contacts (pins) of the memory card.
3. The memory card may not be exposed to heat, direct sun light, and humidity.
4. The memory card may not be bent, twisted, or dropped on the ground.
5. To prevent data losses and/or damages to the memory card, it may NEVER be removed from the device during data transfer. Do NEVER pull the card from the device while data are being written, e.g. during a trip.
6. Make a safety copy of the contents of the memory card on your PC at regular interval.



NOTE

The SD card is specific to the user and should therefore not be used by another person.

To enable a second person to use the ergo_bike pedelec you may order an ergo_memo-card2. Order No. 0017994.

Important folders on your SD card:

\UPDATE: Software update

\DATA\RESULT\PEDELEC: Tour data

\DATA\USER: Specific user and device settings

\DATA\TRACK: Track data

SD Card



ATTENTION

The display must be turned OFF when you remove or insert an SD card (2). Proper operation is only guaranteed for SD/SDHC cards provided by daum electronic. Nevertheless commercially available SD/SDHC cards can often be used.



NOTE

Daum ergo_bike pedelecs combine premium and aesthetical fitness training and biking fun. They bring the proven daum ergometer technology to the roads. Defineable limit values provide for controlled biking and a measured enhancement of endurance and fitness. All the data, for instance the heart rate, trip time, speed, and travelled distance can be stored on an SD card, reviewed and evaluated. An ideal technical prerequisite not only for therapeutic purposes: health oriented users can pedal for preset distances under guidance by the tour manager system (optional) and obtain their individual biological values.



NOTE

Optional software

A special PC software will be made available at no cost on our home page www.daum-electronic.de, under support, for our pedelecs. With this software you can process the tour data saved on your SD card.

An update for our "ergo_win premium pro" software will be made available on our home page www.daum-electronic.de, under support. With this software you can optionally process the tour data saved on your SD card.

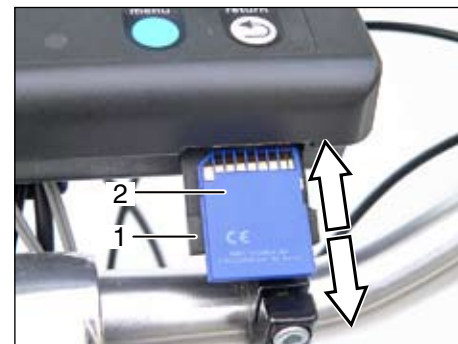

Software update using the SD/SDHC card

- Remove the cover (1) carefully.
- Press the SD/SDHC card (2) slightly to unlock it and pull it out.
- Copy the update file on the card.
- Insert the SD/SDHC card (2).
- When inserting the card, the contact pins must be facing upward.
- Close the cover (1).
- Execute the software update.

Software update with the daum update card

Since the scope of the user software is constantly actualised and expanded, it is possible to bring your device to the latest state by means of a software update. The latest update will always be available as an update file "update.s32" on our internet page www.daum-electronic.de under support, or you can receive an update card directly from daum electronic gmbh.

You can order the update card directly from daum electronic gmbh; once the update is completed you can use the card as a ergo_memo-card2 for a second user.

If you prefer to update over internet, you will need an SD card reader (available commercially or from daum electronic gmbh) and a PC.

Save the downloaded "update.s32" file in the subdirectory /update on the ergo_memo-card2.

Software update



Requirements

If you have an **empty** memory card start here:

- Insert the empty or formatted memory card (1) in the card slot of the dashboard (open the cover in order to have access to insert the card).
- Wait until the card is initialised (confirmation tune will play).

If you have a memory card that is already initialised (the folders \DATA, \MP3, and \UPDATE exist):

- Insert the memory card into the card reader of the computer.
- Copy the update file "update.s32" in the folder \UPDATE on the memory card.

Software update

Software update

- Open the main menu on the dashboard by pressing the menu key, and turn the control button to select the "**Software**" menu option.
- Press the control button and turn it to select the menu option "**Update**".
- Turn the control button to select "**Yes**" and press the control button.

Main menu	
1	Tour data
2	Personal settings
3	Device settings
4	Information
▼	
5	Software

Update	
1	Version
2	Update

- Press the control button.

Update	
The device has the software 1.118/1.118 (dashboard/motor).	
Do you want to update?	
No	▲ ■ ▼
Yes	

Software update

- Turn the control button to select "Yes" and press the control button.
- The dashboard update is executed after.

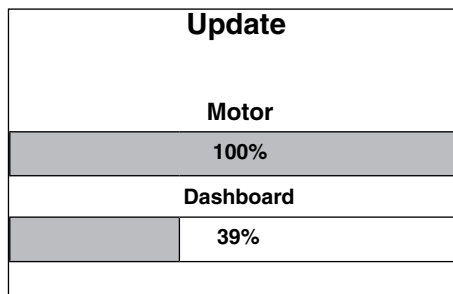
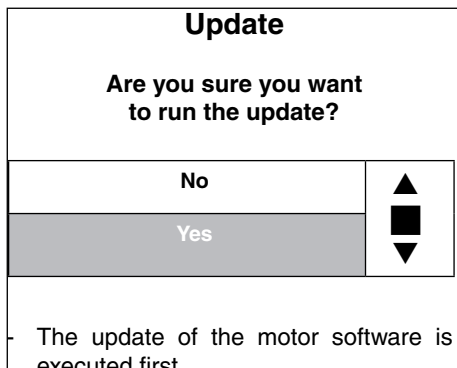

- At the completion of the update the system is reset and the dashboard is restarted.

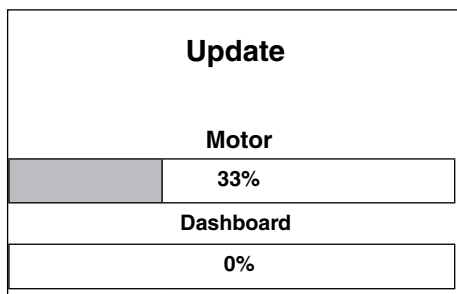

Functions overview

The bikes of the premium series are equipped, in addition to the standard equipment of the classic series, with a combined GSM/GPS module and with a barometric altitude sensor. The GPS module can be used anytime. If the user wishes to use the GSM module he must fit it with a standard SIM card (optional).

Display of travelled tracks on the PC

The collected GPS and altitude data are automatically saved to the SD/SDHC card. These data can afterwards be analysed with the "ergo_win premium pro" software (e.g. what heart rate achieved at which inclination), and exported to Google Earth.

There the complete routing can be represented on the ground, and the user can attach his own pictures and texts.

Travelling through biking tracks from Internet

The ergo_bike pedelec premium connects to the www.GPSies.com web page over GPRS and downloads the biking tracks available for the actual geographical position.

These tracks can then be viewed and selected on the display of the pedelec. This way the most beautiful tracks are always

available to the biker of the ergo_bike pedelec premium, who is automatically guided along them.

Antitheft protection

If an ergo_bike pedelec premium is ever stolen, it is capable of receiving an SMS message from its owner. Then the next time it is turned on it will respond with an SMS containing the coordinates of its geographic location. This will inform the owner of the exact location of his bike.

Bike rental

The operator can locate his vehicle fleet over Internet at any moment. He also has the possibility to generate his own tracks by simply covering them, and then editing them by means of the "ergo_win premium pro" software. He can then deliver these tracks on a SD/SDHC card to his customers, who would comfortably follow them.

Emergency call function

A specific menu option gives the biker of a pedelec the possibility of sending an emergency SMS message with his location information, thus giving away his exact position.

GSM/GPRS



NOTE

GSM stands for Global System for Mobile Communications, GPRS stands for **General Packet Radio Service**.

GPRS is a specific system to transmit information over the GSM network.

This technology is used, for instance, to connect to internet, to download tracks, and to send and receive SMS messages.

To enable this capability the GSM module in the dashboard must be fitted with a standard SIM card.



ATTENTION

If needed ask a daum electronic dealer to install the SIM card for you.

GSM/GPRS



NOTE

The accessories box contains a Power-Bit for the dashboard screws, that can be used with standard tools.

- Unscrew the 6 dashboard screws (1) and the handrails screws (2).
- Lift the upper part of the dashboard until the SIM card socket (3) is visible (on the left side of the dashboard close to the red power switch).

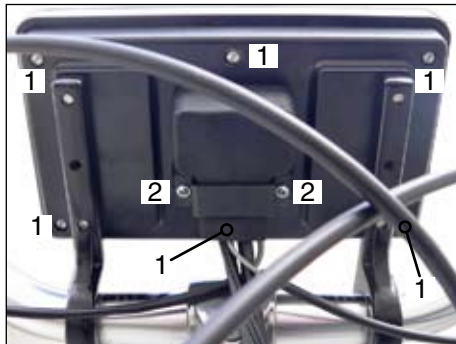

- Be careful to insert the SIM card (4) correctly (watch for the slanted corner).

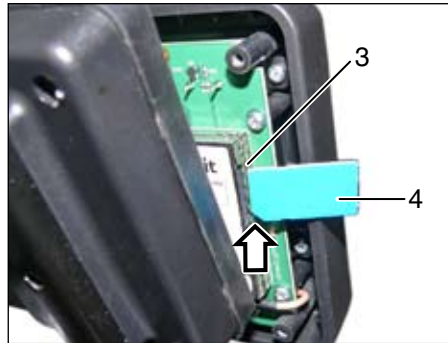

- Insert the SIM card (4) completely until it locks in place.

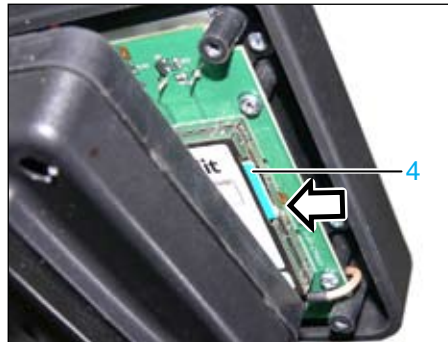

- Close back the dashboard and fasten it with the screws, then turn it on.
- Once the SIM card is recognised by the system, it will ask you to enter the corresponding SIM card PIN.

PIN for SIM card

Please enter the PIN for the SIM card!

--

< - ok

Press return key to deactivate GSM!

- Once you enter a valid PIN the entry field will go away.

GSM/GPRS

- At this point you still have to activate the GPRS (Main menu -> Device settings -> GPRS -> "Activate GPRS").

GPRS	
1	Activate GPRS
2	APN
3	User name
4	Password

- Select option "Yes".

Activate GPRS	
No	▲
Yes	■
	▼

- At the end enter the APN of the provider.

APN
Please enter the APN of your provider!
<p> a b c d e f g h i j k l m n o </p> <p> p q r s t u v w x y z @ . - + </p>
< - ok ABC...

- Subsequently select the "APN" (Access Point Name) option in the GPRS menu.

GPRS	
1	Activate GPRS
2	APN
3	User name
4	Password

APN examples of some providers for GPRS:

Provider	APN / access point name
T-Mobile	internet.t-d1.de
Vodafone	event.vodafone.de
E Plus	internet.eplus.de
Simyo	internet.eplus.de
Fonic	pinternet.interkom.de

Displaying travelled tracks with Google Earth

- Start new tour (pedelec, main menu -> tour data -> **"Start new tour"**).
- Before starting you should confirm that a sufficiently precise GPS position is received ("3D fix, ...").
- Bike through the defined track.
- Start new tour to conclude the travelled tour (Main menu -> Tour data -> **"Start new tour"**).
- Remove the memory card from the dashboard and insert it into the memory card reader of the PC.
- Start the "ergo_win premium pro" software.
- Select the menu option Data -> **"Training results"**.



- Import all the tracks from the memory card (note: the import operation can take several minutes depending on the numbers of data sets).

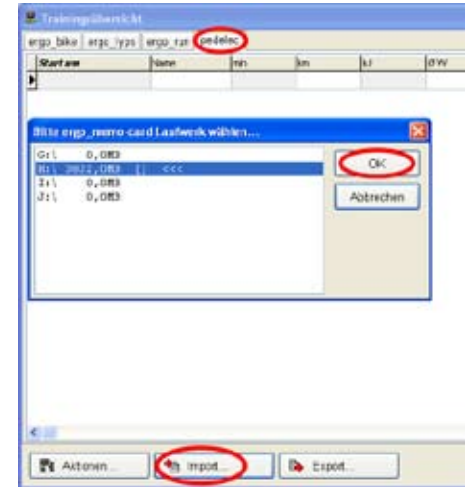

Displaying travelled tracks with Google Earth

- Select the desired tour by means of a double click.

Startzeit	Name	min	km
01.09.2010 10:23:10	STANDARD	75,5	39,1
01.09.2010 08:26:44	STANDARD	36,0	18,7
31.08.2010 17:32:08	STANDARD	34,5	18,9
31.08.2010 08:18:00	STANDARD	41,5	18,8
28.08.2010 08:17:32	STANDARD	81,0	40,8
27.08.2010 08:28:24	STANDARD	99,0	46,2
24.08.2010 16:08:43	STANDARD	48,0	23,7
24.08.2010 08:11:03	STANDARD	37,0	18,7
21.08.2010 14:11:22	STANDARD	99,5	49,3

- Export the selected tour.



- Choose KML as the export format.

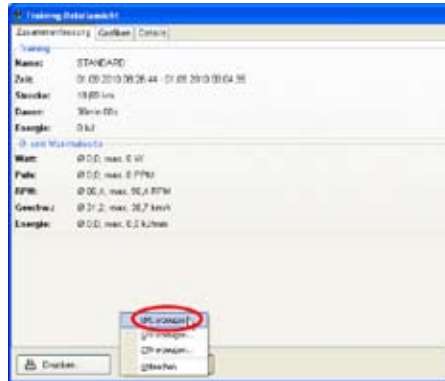

- Open the saved KML file with the Google Earth software.

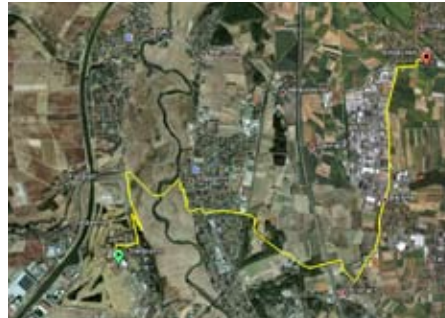

- You can set waypoints or photo positions during the trip.
- You do this by pressing the Scan key during the trip.
- When in a halt, waypoints as well as photo positions can be set by means of the GPS menu.
- You can change the setting by means of the option Main menu -> Device settings -> Scan key.
- The illustration below shows 2 waypoints (black dots with black border).



Displaying travelled tracks with GPSies

- Follow the same sequence as on the pages 30-31, but choose GPX as export format.
- Click the button to upload the GPX file to GPSies (www.GPSies.com).
- Enter the track properties and storage location and then click the save button.



- First set the visibility of the track as "private".

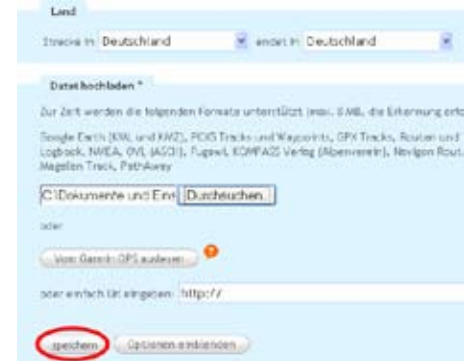

Displaying travelled tracks with GPSies

- Track view in GPSies.

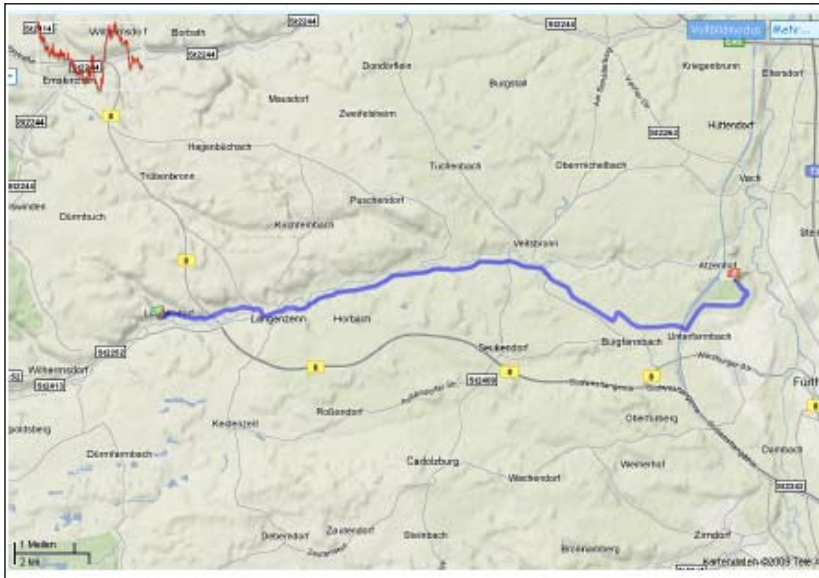

Posting your own tracks on Internet

- Follow the same sequence as described on page 32.
- When uploading a track for the first time you should declare it first as "private".
- After this you should check the track path and correct it if needed ("Edit track", then "Change track").
- When correcting a track you can remove waypoints or move them.
- After the track is corrected as desired, then you can declare it as "public".

GPS menu

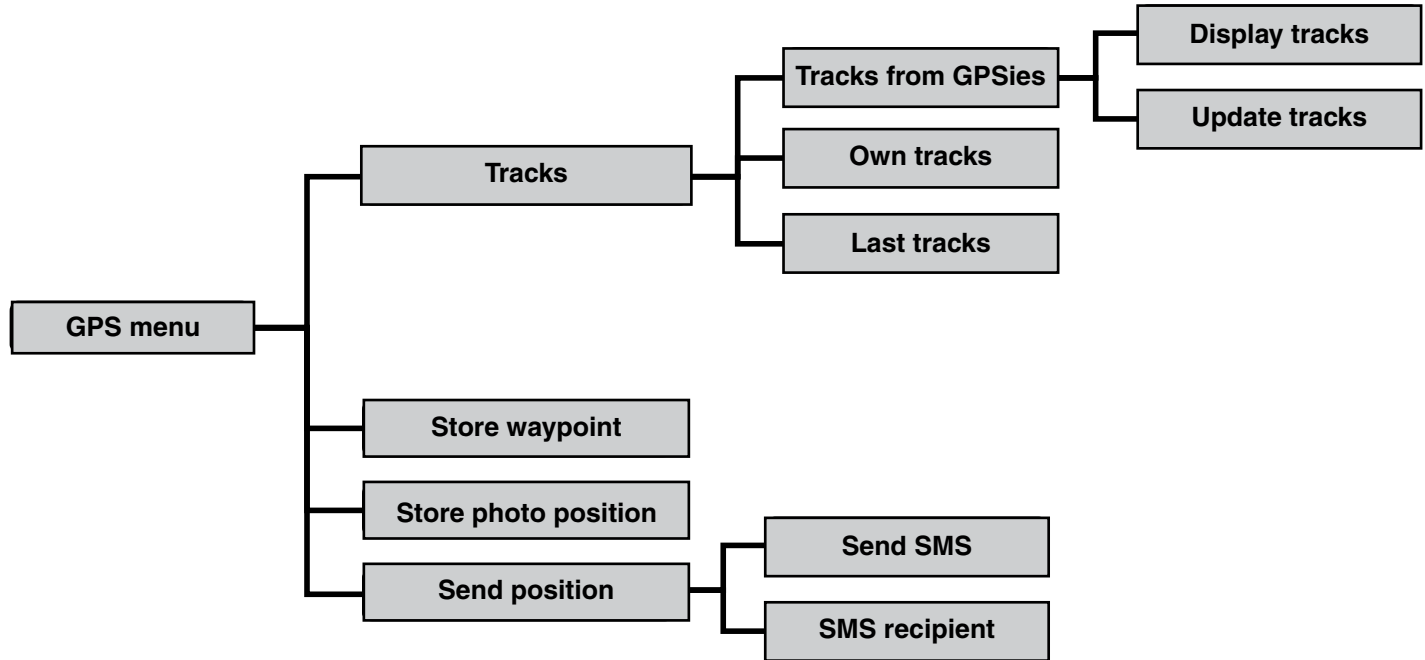

Biking through tracks from Internet

- Press the GPS key to open the GPS menu.

GPS menu	
1	Tracks
2	Store waypoints
3	Store photo position
4	Send position

- Select the "Tracks" menu option.

Tracks	
1	Tracks from GPSies
2	Own tracks
3	Last tracks

- Select the "Tracks from GPSies" menu option.

Tracks from GPSies	
1	Display tracks
2	Update tracks

- Select the "Update tracks" menu option.
- Set the perimeter and number of results.

Update tracks			
Perimeter		Number of results	
020 km	▲	010	
030 km		020	
040 km	■	030	
050 km		040	
060 km	▼	050	

- Choose "Yes" to confirm the "Update tracks" option.

Please confirm	
Do you want to update the tracklist?	
No	▲ ■ ▼
Yes	

Biking through tracks from Internet

- The data transmission starts shortly.
- Select the **"Tracks from GPSies"** menu option.

Data transfer

Sending request to server ...

Please wait for 145 s ...

Tracks from GPSies

1	Display tracks
2	Update tracks

- The following message is displayed at the end of the data transmission.
- Display the tracks (scroll through the tracks by turning the control button).

Update tracks

Tracks are updated!

Display tracks

10	▲	Fürth, Kalchreuth, Kleinsendelbach, Hetzles, Walkersbrunn, Neunkirchen Start 3.2 km/323°, Dest. 3.2 km/323° Length 64.9 km (circular track) Ascent 646 m, Descent 646 m
11		
12	■	
13		
14		
15	▼	

- Press the control button to select the track.

Biking through tracks from Internet

Please confirm

Do you want to download the track?

No	▲
Yes	■
	▼

- The track data transmission starts once you confirm the download by choosing "Yes".

Data transfer

Sending request to server ...

Please wait for 148 s ...

Data transfer

Receiving data ...

11776 Bytes

- The track data are displayed at the end of the data transmission.
- Press the control button to select the track.
- Choose "Yes" if you want to bike through the track.

Select track ...

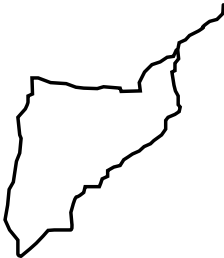

No	▲
Yes	■
	▼

Biking through tracks from Internet

- Once the track is started the system shows the actual GPS position (cross) and the actual track section together at a fixed zoom ratio of 2.0 (see lower line).
- The actual scale is shown in the lower left corner.
- The distance to the track is shown in the upper left corner.
- Start the trip, then once your direction of motion is recognized, the cross changes to an arrow pointing in the actual direction of motion.
- With the help of the arrow you can now move toward the selected track, and then bike through the track in the desired direction with the help of the displayed track guide.
- During the trip you can zoom in to enlarge the track section by turning the control button, to view track details, or zoom out to view e.g. the whole track.

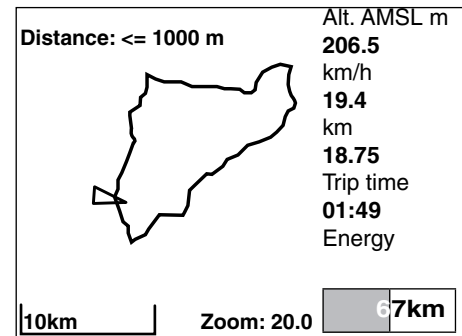
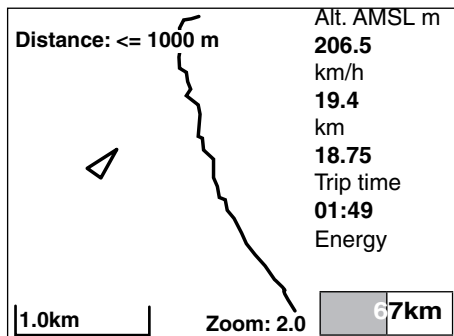
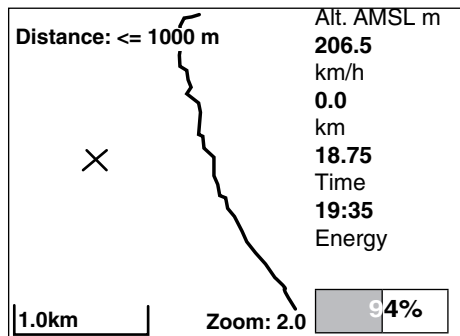

Your own tracks / Last tracks

Tracks	
1	Tracks from GPSies
2	Own tracks
3	Last tracks

You can generate your own tracks, with the "ergo_win premium pro" software, based on tours you have travelled and exported to the SD card. These tracks can then be rerun with the pedelec.

The menu option "**Last tracks**" shows the last travelled "**Tracks from GPSies**" and "**Own tracks**".

With a properly equipped Smartphone (e.g. with the "Opera mini" browser), the position will be directly displayed. You can also open the link on your PC.

Sending the position

In order to display the position of your pedelec, send an SMS message with the word "Position" to the mobile number of the SIM card fitted in the dashboard of the bike. If the bike is on, or the next time it is turned on, you will receive a response with a link.

Sending SMS / SMS recipient

With devices of the premium series from software version 1.110 the position of your device can be informed and a SMS be transmitted by means of the GPS menu option "**Send position**".

- Enter the phone number of the desired SMS recipient by means of the option "**Send position**" -> "**SMS recipient**".
- Put the country code in front, e.g. +49 for Germany (then drop the leading zero of the mobile phone number).
- Then select one of following short messages by means of the option "**Send position**" -> "**Send SMS**" and send out by pressing the control knob.
 - > "**Injured**" ("I am injured. My position is ...")
 - > "**Break down**" (My bike is broken, please pick me up. My position is ...")
 - > "**Pick up**" (Please pick me up! My position is ...")
- In the transmitted SMS message the GPS information (Latitude and Longitude as well as date yyyy-mm-dd and time T 00:00) will be added automatically.

Determining the altitude

The pedelec is equipped with a GPS module and a barometric altimeter to determine the altitude above sea level. The GPS module is too inaccurate for a continuous display of the altitude, since depending on the position and on the number of received satellites, the altitude determined by GPS can vary by more than 100m (e.g. between high buildings, in a dense forest, or under heavy clouds).

The expected vertical deviation depends on the number of received satellites and their locations. The number of received satellites oscillates normally between 5 and 12. Under very favourable receiving conditions the vertical accuracy is in the range of about +/-10m; under normal receiving conditions +/- 20m.

When starting a new tour, we recommend to wait until a valid GPS position can be determined, which will be used as start altitude. Otherwise no valid altitude will be displayed. The accuracy is generally sufficient, but can vary as explained above.

Determining the altitude

If you want to have a more accurate evaluation of the start altitude then please wait until enough satellites are received (Scan display / GPS data).

Start a new tour to use the more precise altitude from the GPS module as the start altitude for the barometric altitude sensor. During the tour the altitude measured by the barometric sensor is used and displayed.

If the bike is parked for an extended period of time during a tour (e.g. at the lunch break), and the weather conditions change markedly during this time, this will have no effect on the altitude recorded, because variations of the air pressure are ignored when the bike is not moving. You need not worry about the system recording a variation of the altitude value while taking a rest break.

Depending on the weather conditions the following deviations in the measured barometric altitude are to be expected:

- in the case of an unstable high pressure area > 25 m/h
- in the case of stable good weather 5 to 25 m/h
- in the case of stable weather -5 to 5 m/h
- in the case of stable rainy weather -25 to -5 m/h
- in the case of an unstable low pressure area < -25 m/h

GPS data

Latitude:	49.503538°
Longitude:	10.963827°
Altitude AMSL:	314.7 m
Satellites:	7 Fix,
HDOP:	3D, 1.2

Current data

Trip time:	00:00:00
Heart rate:	---
Temperature °C:	19.8
Altitude AMSL:	322.4
Incline %:	0.0

Fix and HDOP are described under

- Fix: http://www.faq.daum-electronic.de/cgi-bin/faq.pl?faq_id=00000320
- HDOP: http://www.faq.daum-electronic.de/cgi-bin/faq.pl?faq_id=00000321

During the trip this altitude value is much more precise than the one obtained from the GPS module, provided the weather conditions (air pressure, temperature) do not change significantly.

Starting up

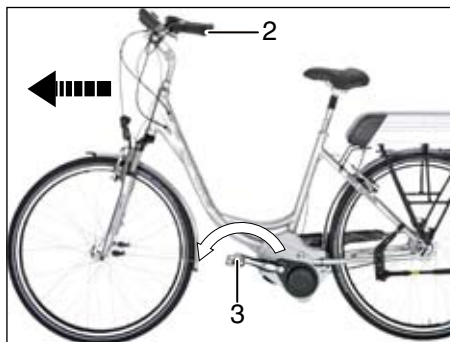
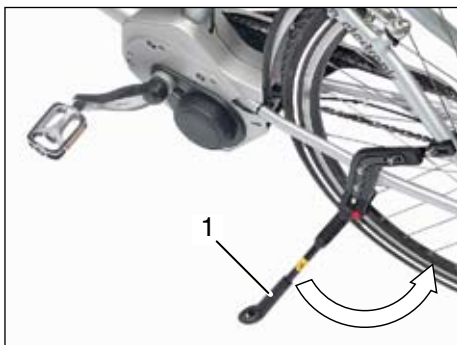

WARNING - FALL RISK!

A fall with heavy injuries could be the consequence of not complying with the following directives:

- Fold up the side stand (1).
 - Hold the handlebar (2) in the straight ahead position before you set off.
 - Start first with the motor switched off to practise and gain acquaintance with the bike. Switch the motor on only while driving.
- Start pedalling (3) only after you have taken a safe sitting and driving position.
 - When setting off in a curve or when negotiating tight curves pull lightly the hand brake lever. This will interrupt motor assistance and ensure safe driving.

Assistance level



After switching the dashboard ON you can select the assistance level by means of the specific keys (1 and 2).

Assistance level (4) on the display:

- off** (without motor assistance)
- low** (with motor assistance)
- normal** (with motor assistance)
- high** (with motor assistance)

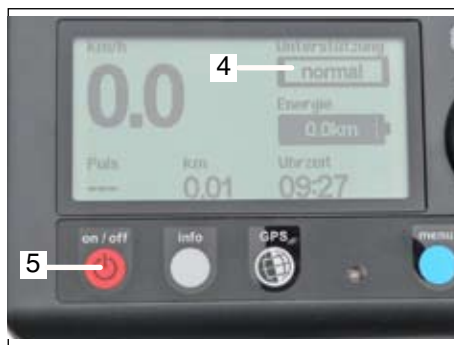

NOTE

If the bicycle is stopped or parked, after about 2 minutes the display is first put into standby, and after about 10 minutes the whole electronic system goes into standby mode.

To reactivate the display or the drive system press the red ON/OFF key (5).

In the case of extended upward trips the motor can run so hot that the temperature sensor in the motor reduces the electric power to the motor and thus the motor assistance decreases.

Pushing assistance

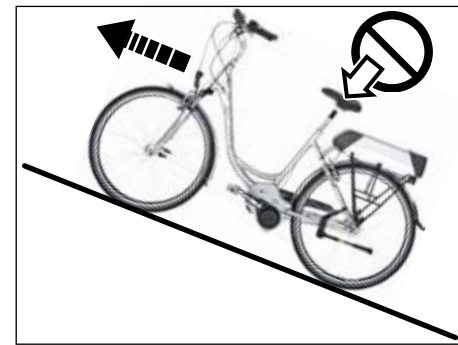

ATTENTION

Use the pushing assistance (3) only when you are not sitting on the bicycle.

You can use the pushing assistance in the cases where riding the ergo_bike is too hazardous, e.g. in the case of a high slope or rough terrain.

The assistance provided depends on the slope, i.e.:

large slope	high assistance
little slope	low assistance

On larger slopes, pushing the ergo_bike pedelec will be easier.

Pushing assistance



This function can only be activated at < 6 km/h. If the speed exceeds 6 km/h while pushing assistance is active, then it will be turned off.

- Shift into first speed (gear) before activating the pushing assistance function by pressing the key (1).
- The pushing assistance is deactivated by pulling one of the brake levers (2) or by pressing the corresponding key (1).

Driving conditions

Motor assistance		
Muscle power		
up to about 20 km/h Full motor assistance proportional with the assistance level	from about 20 km/h to about 25 km/h Motor assistance decreases	from 25 km/h Muscle power only



NOTE

The motor drive of your ergo_bike pedelec is equipped with a high-quality two-levels transmission, that lowers (demultiplies) the rotational speed of the powerful motor (up to 3700 RPM) to the pedalling speed range. This ensures you an easy start in most situations.



ATTENTION

The transmission noises will diminish to a minimum only after a running-in distance of about 100 kilometres.

The bicycle can be used with or without switching on the power assistance.

With the power assistance switched on you start pedalling like with a normal bicycle. When you start pedalling, the electric motor kicks in and helps accelerate the bicycle. The stronger you pedal, the stronger the motor assistance will be.

In the speed range from about 20 to 25 km/h the motor assistance is reduced.

From about 25 km/h the electric motor is set to idle, there only muscle energy will be available.

8-speed hub gear

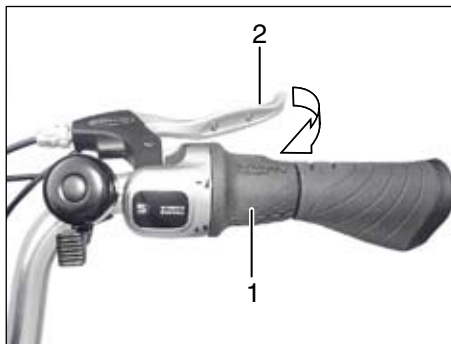
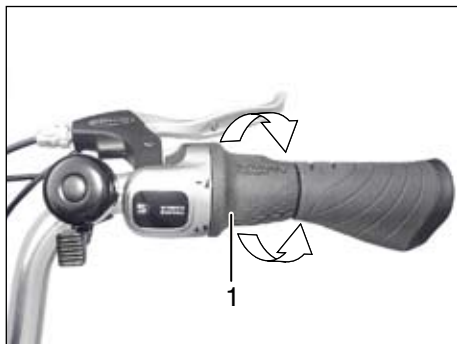

Operation

The twist grip shifter (1) is easy to use and enables precise shifting with the 8-speed hub gear.

Shifting

- Stop pedalling while you shift speed.
 - + : 1 x shift for the next higher speed.
(The eighth speed has the highest transmission ratio.)
 - : 1 x shift for the next lower speed.
(The first speed has the smallest transmission ratio.)
- Shift to a lower gear at the right moment before a slope.

The transmission will not shift under motor load.



ATTENTION

Please consider the following before shifting to the next gear with the twist grip shifter (1):

- **It is not enough to stop pedalling because the electric motor continues to drive the transmission for about 2 to 3 seconds.**
- **You should either wait till the motor stops driving or pull shortly one of the two brake levers (2) before shifting.**

Recommends

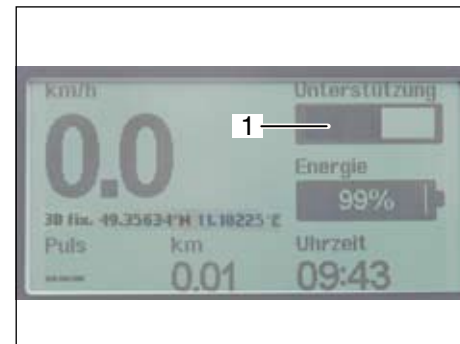

The length of the bar (1) in the upper right corner of the display indicates the actual energy consumption. The length of the bar increases with the energy consumption. You will be biking most efficiently, and have shifted to the optimal gear, when the actual energy consumption lies within the center third area.

If the bar drops to the lower third (left side) during a trip, then you should shift to a higher gear. If it lies often in the higher third (right side) then you should shift to a lower gear.

Braking

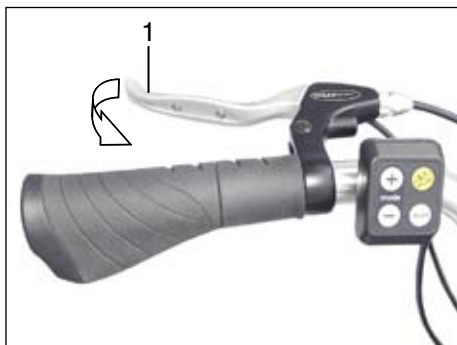

Hand brake lever for front wheel brake (1)

The brakes for the front wheel and the rear wheel can be used independently from each other. To stop or reduce the speed pull both hand brake levers (1 and 2) simultaneously.



NOTE

Motor assistance is immediately interrupted when you brake.

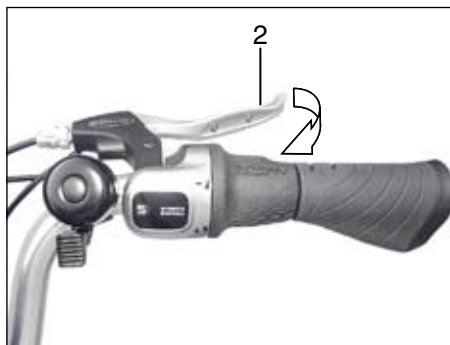

Hand brake lever for rear wheel brake (2)



WARNING

The pedelec is equipped with V-brakes, which can achieve very high braking power.

In tight curves, on sandy or greasy streets, on wet asphalt, and on black ice you should be very careful when using the front wheel brake to avoid skidding the front wheel.

Please use the brake with moderation. Blocked wheels have a lesser braking effect and can lead to skidding and falls.

Do not brake in curves, but rather brake before entering them!

Braking in a curve increases the risk of skidding.



NOTE

In order to be ready for “emergency situations”, practise braking in places where you will not expose yourself and others to hazardous situations (e.g. on driving practising grounds).

Parking and securing the ergo_bike pedelec

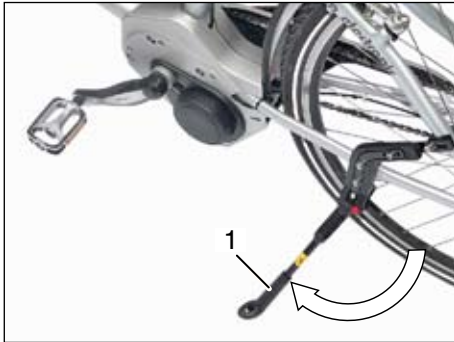

ATTENTION

When unfolding the side stand (1) always be sure to have a secure position and a stable ground in order to prevent tilting over.

- Switch off the dashboard and motor by pressing the ON/OFF key (1).



ATTENTION

Whenever the ergo_bike pedelec is parked, always remove the key.

- Open the cover (2) of the rechargeable battery compartment.
- Turn the rechargeable battery key (3) clockwise into position.  This locks the rechargeable battery and switches it off.
- Remove the key.
- Close the cover (2) of the rechargeable battery compartment.

Safety hints

Traffic security

According to the Road Traffic Licensing Regulations, a bicycle must be equipped with two functional brakes, independent from each other, a clearly audible alarm bell (chime), a headlight, a tail lamp, reflector pedals, lateral reflectors for the wheel or integrated reflecting stripes on the wheels as well as front and rear reflectors.

This bicycle is intended only for driving on paved roads. Do not use it then offside of paved roads or on rough terrains.

Do not use this bicycle to cross water surfaces, to cross terrain gaps, and in sporting events.

While driving you should keep in mind that for an average speed of about 18 km/h the distance covered is 5 meters per second. Keep accordingly a sufficient interval to other road users.

For your own safety do not drive with your hands off the handlebar and not close to the side of other road users.

You must be able to hear warning noises. To this end do not use headsets or earphones while on the road.

Safe driving

The following, among other, contributes to a safe driving experience: the proper setting of the saddle and handlebar level according to your physical size, adjusting the tyres to the prescribed inflation pressure, sufficient tyre tread depth, and faultless operation of the brakes and lights.

The fastening parts "set down" after some time. It is then recommended before using the bicycle and every 6 months to check the proper fastening of axle nuts, steering bearing, handlebar, saddle, saddle pillar, pedal cranks and pedals, and if needed to let your daum electronic dealer retighten them. See the following sections:

- Disassembling and assembling the front wheel
- Disassembling and assembling the rear wheel
- Steering bearing
- Adjusting the handlebar
- Adjusting the saddle
- Saddle height
- Pedal crank and pedals

The gear shift and brakes should be regularly checked by your daum electronic dealer.



ATTENTION

For the sake of your own safety use only accessories certified by daum electronic and original spare parts for your bike. These accessories and spare parts were specially tested regarding their safety, suitability and reliability with this bicycle.

We cannot evaluate this suitability for other accessories and parts in spite of our continuous market monitoring, and thus cannot be liable for them, even if in some individual cases these parts or accessories received technical approval of a recognised technical inspection agency or received the approval of a state certified agency.

If it were necessary to replace lighting parts or pedals, please note that only parts with the official proof mark are approved. The proof mark (wavy lines with the letter "K" and a 5 digits number = ~ K.....) is always placed on the spare part. Please use only original spare parts.

Safety hints

Do never straighten any damaged or bent security relevant parts like e.g. frame, fork, handlebar, saddle pillar or pedal cranks, but instead have them replaced before using this bicycle. There is a risk of fracture. In case of doubt please consult your daum electronic dealer.

Is the ergo_bike pedelec in proper state?

Before every trip with the ergo_bike pedelec you should verify that it is in a faultless state. To that effect you should carry out the following tests (please read the complete explanation to each point below in the corresponding section):

- Is the saddle clamp firmly attached to the saddle? (see section "Adjusting the saddle")
- Do the brakes operate without fault?
- Is the light system operational?
- Is the rechargeable battery correctly locked in the battery compartment?

Carry out the following tests at regular intervals:

- Is the tyre pressure correct? (see the section about "Dismounting and mounting the tyres")
- Is the bike chain in proper condition? (see the sections "Verifying chain wear" and "Bike chain tension")
- Are the steering bearing and the pedal cranks in proper condition? (see the sections "Steering bearing" and "Pedal cranks")
- Are all the spokes firmly seated? (see the section "Spokes")

Verify after a fall or accident that no part is bent or distorted or damaged (the frame, the handlebar, the wheel rims, etc.).

If any one of the elements mentioned above is not in proper operating condition then please avoid using the bike. The defects must immediately be repaired. If you can not repair the defect yourself then please contact your daum electronic dealer.

Safety hints

What should I consider while driving?

If your bicycle is in proper operating condition then you can ride it and go. Now it depends on your driving behaviour and capacities to avoid hazardous situations:

- You should first get thoroughly acquainted with your bicycle.



WARNING

Hold the handlebar in the straight ahead position before you set off.

Start first with the motor switched off to practise and gain acquaintance with the bike. Switch the motor on only while driving!

- Always comply with the traffic regulations.
- Do never drive on the offside of paved roads.
- Do not drive in the dead angle region of other vehicles.
- Do give signal early enough about the direction you intend to take.

- Keep in mind that the manoeuvrability of bicycles can surprise other road users, and take into account the potential errors of the other road users.
- Adopt a defensive driving technique and adapt it to the circumstances around you.
- Hold the handlebar firmly with both hands. This way only you will have the possibility to react promptly and safely to sudden hazardous situations like e.g. obstacles.
- When driving on sandy ground, on foliage or grass and on wet roads, take into consideration that tyres have less adherence to the ground than on dry asphalt. Keep this in mind when taking a curve or braking in order to prevent skidding. Keep also in mind that braking to a stop will take a longer distance.
- Shift down the gear in time before climbing slopes.

What should I wear?

Many accidents occur because cyclists are not recognised at the right moment. It is therefore sensible to wear bright and noticeable garments. Be careful not to wear loose clothes that can catch and remain hanged up on the bike chain, on the handlebar, on the pedals or on the wheels.

It should be self-evident to you that you always wear a helmet. Make sure that your helmet complies with the safety standards SNELL and ANSI, or with the newer ECE standard. To protect your eyes wear bicycle glasses.

Transport

The ergo_bike pedelec may only be transported standing on its wheels.

We recommend the use of an appropriate car bike rack.

Before you transport your ergo_bike pedelec on the roof or on the rear end of your car, please remove in any case all parts that can get loose during the transport (rechargeable battery, tool bag, etc.).

Theft protection

Secure your ergo_bike pedelec with an additional cable lock against theft, and attach it only to fixed installations like e.g. street lamps or metal fences.

The lock should secure the frame and the rear wheel. Make sure that the lock tightly encloses the bicycle and the fixed installation. The keyhole should face downward to protect it against humidity.

Remove and take with you all loose parts like e.g. drinking bottle, air pump or tool bag.

Carrying loads

Carrying loads in any form modifies the road handling of the bicycle. The heavier the load, the more critical this modification will be.

Loads (shopping bags etc.) should not be attached to the handlebar, but rather to the carrier rack provided.

Consider the total allowable load carrying capacity of the ergo_bike pedelec.



WARNING

- **Do not carry cumbersome loads.**
- **Do not cover the lighting.**
- **Do not take passengers (persons).**
- **Do not hitch a trailer.**

Bicycle care / care products



NOTE

Regular and competent care helps the bicycle keep its value and is one of the requirements for accepting warranty claims. Corrosion as a result of lack of care or because of winter operation is not covered by the warranty.



ATTENTION

Do not use aggressive or penetrating cleaning substances and solvents on rubber and plastic parts, as this could damage them.

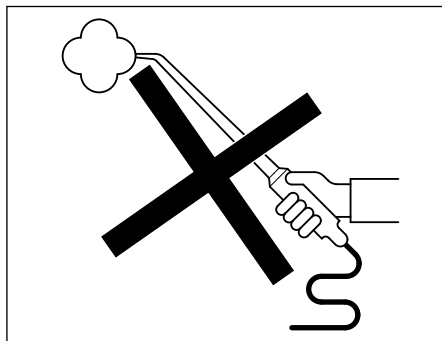

WARNING

After cleaning and before using the bicycle always perform a brake test.



ATTENTION

Do not use steam or high pressure jet devices.

High water pressure can cause damages to the journals (pads), to the sealings, to the rechargeable battery and to the complete electric system.

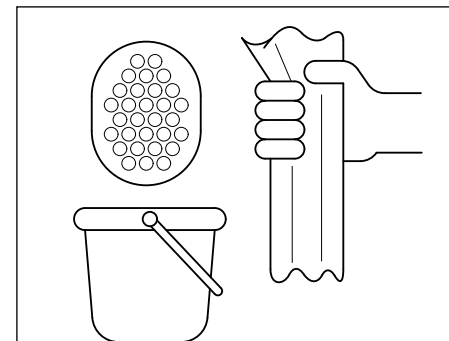

Cleaning

- Use only a soft sponge and clear (pure) water to wash the bike.
- Use only a soft cloth or leather for polishing.
- Do not use a dry cloth to remove dust and dirt (this may cause scratches on the painted parts or on the casings).

Bicycle care / care products

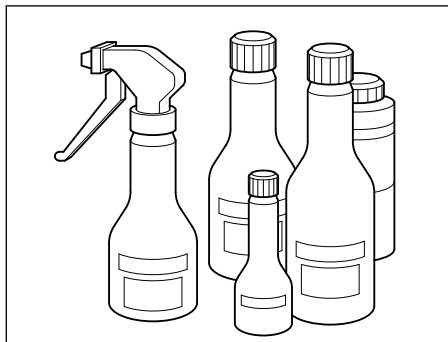

Care products

When needed you should care for the bicycle with standard commercially available preserving agents and care products.

- Apply preventive treatments of preserving products and care products to parts exposed to corrosion, primarily and regularly in winter.



ATTENTION

Do not use care products containing silicone, and paint polishing products on plastic parts.

- Clean thoroughly the frame and aluminium parts after longer trips and apply a standard commercially available corrosion protection agent.

Winter operation and corrosion protection



NOTE

For the sake of environment protection you should use care products sparingly, and choose those products that are identified to be environmentally friendly (ecological).

If the bicycle is used during the winter months, considerable degradation can be caused by road salt.



ATTENTION

Do not use warm water – this would increase the salt action.

- Clean the bike with cold water immediately after a trip.
- Dry the bicycle thoroughly.
- Apply wax based corrosion protection agents on parts exposed to corrosion before using the bike, and repeat eventually several times.

Repairing paint defects

Repair immediately small paint defects with a paint stick.

Tyre care

If the bicycle is not used for an extended period of time, we recommend to store the bike in such a way that the tyres are not loaded.

Do not store the bicycle or the tyres for an extended period of time in very hot rooms like a basement boiler room.



ATTENTION

The tyre tread depth may not drop under 1 mm.

Driving over kerbstones, sharp edged obstacles, ground depressions, potholes, etc. can cause damages to the wheel rims (spoke break) or to the tyres (wall cracks), whereas a too low tyre pressure can also have the same causal effect.

Warranty claims for these effects are not accepted.

Disposal of waste



NOTE

After the implementation of the European Directive 2002/96/EU in the national legal system, the following applies:

Electrical and electronic devices may not be disposed of with domestic waste.

Consumers are obliged by law to return electrical and electronic devices at the end of their service lives to the public collecting points set up for this purpose or to the daum electronic dealer. Details to this are defined by the national law of the respective country.

The symbol on the product points out these regulations.



**Rechargeable
battery**

Li-Ion

By recycling, reusing the materials or other forms of utilising old devices, you are making an important contribution to protecting our environment.

In many countries the waste regulations mentioned above apply to batteries and rechargeable batteries, and are recommended for the international countries as well.

Rechargeable battery

Rechargeable batteries are subject to the waste disposal byelaw. They contain toxic heavy metals and are consequently subject to the special waste management byelaw. Your daum electronic dealer will carry out the disposal for you.

Battery charger

Dispose of this device in conformity with the environmental regulations enforced in your country. Electrical waste may not be disposed of with domestic waste.

You will obtain information from your local authority or your daum electronic dealer.

When the charger reaches the end of its useful life, make the device unusable by pulling the power plug from the power outlet and cutting the power cable.

Other components

Dispose of other components in conformity with the environmental regulations enforced in your country.

Electrical and electronic devices may not be disposed of with domestic waste. Please ask your local authority or daum electronic dealer for recommendations and tips regarding recycling.

Technical modifications, spare parts, accessories

If you want to undertake technical modifications then you must comply with our directives. This ensures that no damage will be done to the ergo_bike pedelec, that traffic and operational safety are maintained and that the modifications are approvable. Your daum electronic dealer will execute these works diligently.

Before buying accessories and before carrying out any technical modification you should always seek advice from your daum electronic dealer.



ATTENTION

For the sake of your own safety use only accessories certified by daum electronic and original spare parts for your daum electronic ergo_bike pedelecs.

These accessories and spare parts were specially tested regarding their safety, suitability, and reliability with this ergo_bike pedelec.

We cannot evaluate this suitability for other accessories and parts in spite of our continuous market monitoring, and thus cannot be liable for them, even if in some individual cases these parts or accessories received technical approval of a recognised technical inspection agency or received the approval of a state certified agency.

Approved accessories for your daum electronic ergo_bike and original daum electronic spare parts are available at your daum electronic dealer.

Your dealer will also carry out the installation professionally for you.

Accessories

Spare rechargeable battery



Lithium-Ion technology, 9.5 Ah, 36 V, with a set of two keys

Order No.: M0041703.0001

Chest belt



The digitally encoded heart rate transmission system sends the heart rate data reliably at a frequency of 868 MHz to the dashboard from a distance of up to 3 m, enabling a heart rate controlled ride of the ergo_bike pedelec. Easy to use and comfortable to wear.

Order No.: 9091036

Accessories

SD card



ergo_memo-card2

Order No.: 0017994

Shopping Basket



The KLICKfix basket can easily be mounted on the handlebar with just a click and comes with a matching handlebar adapter.

Order No.: 9091041

Luggage Bags

Laptop and Office Bag



Equipped with magnetic press-in lock and additional zipper, two zipper compartments and side pockets, detachable inside pocket, carry handle, shoulder strap. Volume: 16 litres. Dimensions: L40 x H32 x W12 cm. Fastening system: vario hooks.

Order No.: 9091042

Shopping Bag



Colour: black/granite
Equipped with outside pocket, reinforcement, zipper, carry handle, reflective stripes. Volume: 15 litres. Dimensions: L36 x H32 x W15 cm.

Order No.: 9091043

Trekking Bag



Colour: black/granite
Equipped with water repellent tarpaulin fabric, inside frame and reinforcement of unbreakable PE material, outside pocket, carry handle, reflective stripes, reflective push button. Can be used on either side of the carry rack. Volume: 17 litres. Dimensions: L30 x H32 x W16 cm.

Order No.: 9091044

Miscellaneous

WARNING

Safety requirements prohibit you from undertaking repairs and adjusting works on your own, except for a narrowly delimited scope. Improper or unqualified work on safety sensitive parts compromises your own security and that of other road users.

This applies particularly to work executed on: steering, brake system and lighting.

ATTENTION

Remove the rechargeable battery from its compartment before executing any work on the electrical system. Do not undertake any work on the electronic system. Failure to comply with these recommendations will void the warranty.

Any intervention or disassembling work done on the motor unit, cable harness, rechargeable battery and battery charger will void the warranty.

Please take the following into account:

- Maintenance works during the warranty period and afterwards should always, without exception, be executed by an approved daum electronic dealer.
- Use only original daum electronic spare parts.



NOTE

Please consult our service and repair notes on internet at www.daum-electronic.de if you wish to obtain more information about your product (ergo_bike pedelec).

You can also call our central office at daum electronic gmbh, phone no. +49 (0)911 / 9 75 36-0.

The maintenance plan describes the various maintenance operations.

D = by your daum electronic dealer

O = by the owner

Maintenance and care plan

D = maintenance work executed by your daum electronic dealer

O = verification done by the owner

Works to be executed	Page	before using the bike	monthly	yearly	when needed
Checking all the screws, bolts and nuts that are important for safety and operation, to make sure they are properly seated and tightening them when needed: Axle nuts, steering bearing, handlebar, saddle, saddle pillar, brake, pedal cranks		O	O D		O D
Bike chain, verifying chain tension and adjusting when needed. Cleaning and lubricating with bike chain spray. Verifying the alignment of the rear wheel and adjusting it when needed.	59-60		O D		O D
Verifying the steering bearing.	62	O			O
Verifying the steering bearing and adjusting it when needed. If needed re-lubricate and adjust.	62		D		D
Verifying the sheated cables.		O			
Verifying and adjusting the sheated cables.				D	D
Lubricating the side stand.				O D	O D
Checking the operation of the braking system.	63-65	O			O
Checking the operation of the braking system and adjusting it when needed.	63-65				D

Maintenance and care plan

<p>D = maintenance work executed by your daum electronic dealer O = verification done by the owner</p>					
Works to be executed	Page	before using the bike	monthly	monthly	when needed
Braking system When the braking system is not operating properly, verify the state of the hand brake levers, sheated cable and brake arms, and adjust them when needed. Lubricate the joints and bearings. Replace cracked or jammed sheated cables. Replace oiled brake linings, even minimal oiling means a reduction of braking effect.					D
Verifying the wheel rims and spokes for lateral and radial run-out.	62	O			
Verifying the wheel rims and spokes for lateral and radial run-out. Checking the spokes tension and adjusting it when needed.	62		D		D
Checking tyre air pressure regularly.		O			O D
Checking tyre tread depth.	52				O D
Verifying lighting and signalling systems including head light, and adjusting them when needed.	71	O			O D
Recharging the rechargeable battery with the charger.	38-40	O			O
Test ride before and after the execution of works to verify the general operational state and traffic safety.		O			O D

Bike chain tension

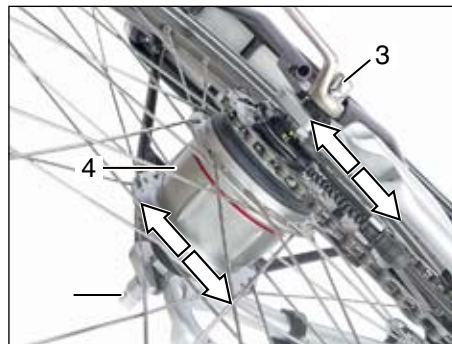
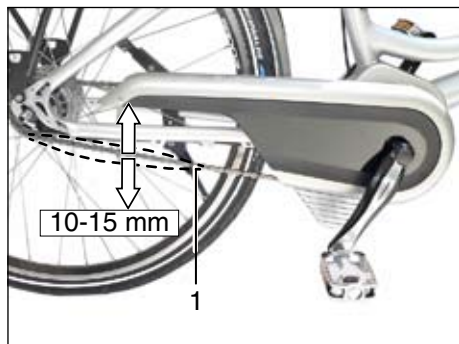

Verifying

- Place the ergo_bike pedelec on the side stand.
- The chain (1) must move 10 to 15 mm max. up or down when pushed.

If the chain is too loose or too tight it must be corrected.

Adjusting

- Loosen the axle nuts (2 and 3) on both sides by means of a ring spanner wrench. SW 15 and adjust the chain tension by shifting the rear wheel (4).
- Before tightening the axle nuts you must check that the front and rear wheels are exactly aligned (both run on one single line).
- Assembling is executed in the opposite sequence.
- Verify chain tension one more time.
- Check the proper seating of the left (3) and right (2) side axle nuts one more time.

Tightening moment of the axle nuts about 40 Nm.



ATTENTION

Please let your daum electronic dealer check the bike chain tension.

Verifying chain wear



Under correct chain tension the chain may be lifted no more than 3 mm from the base of the sprocket.

Even the very best bike chain has a limited usable life.

If after adjusting and lubricating all parts you do not obtain a satisfying chain run we recommend replacing the worn out chain.

- Place the ergo_bike pedelec on the side stand.
- Relax the chain tension (see adjusting the chain tension).
- Assembling is executed in the opposite sequence.



NOTE

You should not use a new chain with worn out chain sprocket and pinion. This combination will produce clicking noises.

In that case it is advisable to replace the chain and the chain sprockets and pinions together.



ATTENTION

These works are to be executed by your daum electronic dealer.

Pedal cranks

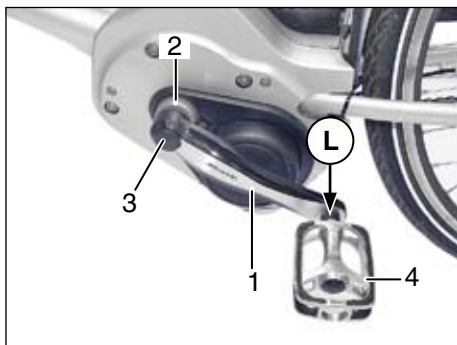

WARNING

If you determine that the pedal cranks or the bottom bracket are loose please consult your daum electronic dealer.

The pedal cranks (1) can get loose with time and extended driving. Check regularly if the pedal cranks are firmly seated. There should be no perceivable play (slack) when you strongly laterally pull the pedal crank.

The bottom bracket (2) must also present no play (slack) and the pedal crank must rotate easily, in that case the bearing is in proper condition. Verify the bottom bracket regularly. To perform this verification move the pedal cranks laterally back and forth.

The pedal cranks are tightened to a max. moment of 35 Nm.

Tightening:

- Remove the protective caps (3) on both sides and have the screws located underneath them tightened.



NOTE

If the pedal cranks are already loosened then the internal square drive is generally already deflected. The pedal cranks and eventually the axle must then be replaced. Disassemble well seated pedal cranks only with a crank extractor, do never use force to knock them out.

Before proceeding with the installation, the square bearing surfaces of the crank and axle must be completely oil and grease free.

Pedals

Verify regularly that the pedals (4) are firmly screwed to the pedal cranks. Keep in mind that the pedals have different threading.

The left side pedal is equipped with a left-handed thread; it is tightened counter-clockwise.

The right side pedal is equipped with a right-handed thread; it is tightened clockwise.

The pedal axles are marked accordingly: (L) for the left side, (R) for the right side.

Tighten the pedals (4) with a fork wrench SW 15.

Steering bearing

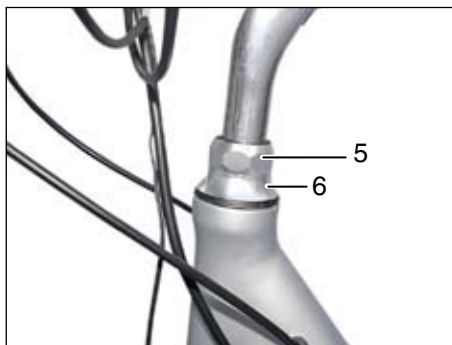
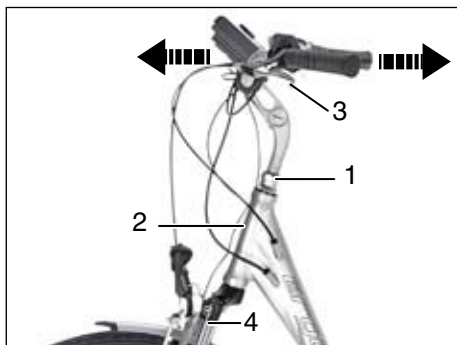

WARNING

Respect the inspection intervals. In the case of prolonged driving with a loose steering bearing (1) a break of the fork stem (2) may not be excluded. The consequence could be a fall with heavy injuries. Please let your daum electronic dealer execute this adjustment, a special tool is needed for this operation.

Verifying:

- Pull and hold the hand brake lever (3) and move the bike back and forth.
- If a play in the steering bearing (1) is noticeable, then it must be adjusted.

Adjusting:

- Loosen the top nut (5) and pull it upward.
- Tighten the steering cone (6) until the play is eliminated.
- Tighten the top nut (5).



NOTE

The front fork (4) must not grip (clamp) at the steering stop (extremity) and must pivot easily in both directions.

Spokes



ATTENTION

Replacing, tensioning or loosening of wheel spokes must be done by your daum electronic dealer.

A tight seating of the spokes (1) is important to ensure a smooth running of the wheels. Have your loose spokes timely retightened.

Broken spokes and the spokes opposite to them must be immediately replaced and the wheel must be recentred, or eventually equipped with new spokes completely.

Spoke break and unbalance of the wheel is often the result of an improper tensioning of the spokes.

Positioning the hand brake levers

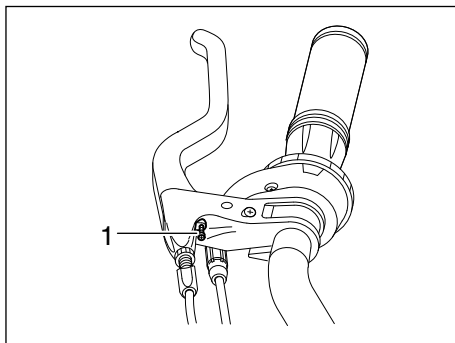

The position of the hand brake lever relative to the handlebar grip can be adjusted by means of the stop screw (1) .

Adjusting the hand brake levers

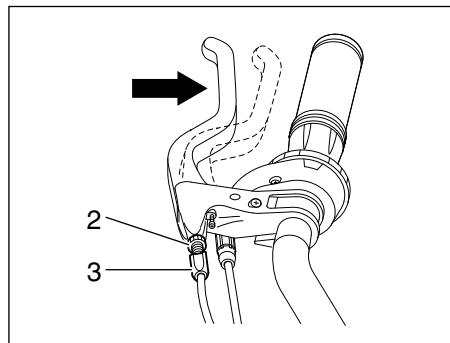

⚠ WARNING
Adjusting the brake is absolutely necessary when the hand brake lever can be pulled almost all the way to the handlebar grip without producing a noticeable braking effect.

- Loosen the counter nut (2).
- Turn the setting screw (3) outward until an interval of about 1 mm between the brake shoe and the wheel rim is achieved.

Detaching the brake cable down

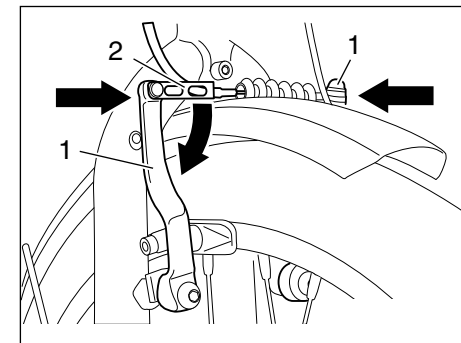

- Press both brake arms (1) together and pull the brake cable guide (2) out of the holder.
- If it is not possible to pull the brake cable guide, tighten the setting screw on the brake lever until it becomes possible to pull the brake cable guide.

Disassembling and assembling the brake linings

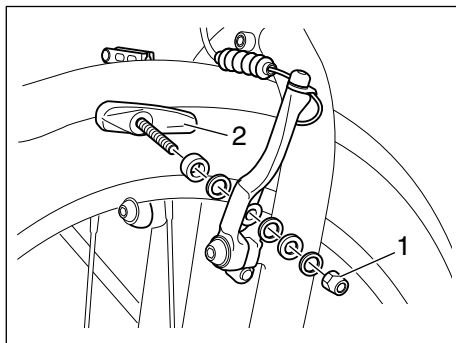

Disassembling

- Detach the brake cable.
- Unscrew the nut (1), remove the washers and the brake shoe (2).

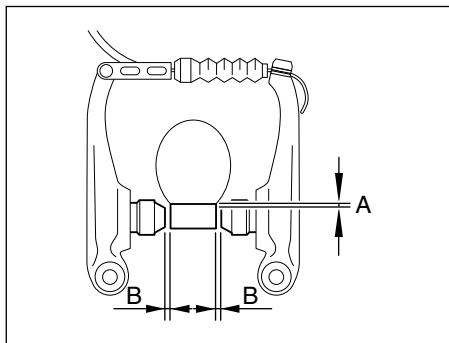

(A) = 1 mm, (B) = 1.5 mm

Assembling

- Install the brake shoe with the washers and nuts and tighten lightly.
- Adjust the brake shoe such that the interval (A) from the upper edge of the wheel rim equals 1 mm and the interval (B) between the brake shoe and the wheel rim equals 1.5 mm on both sides.

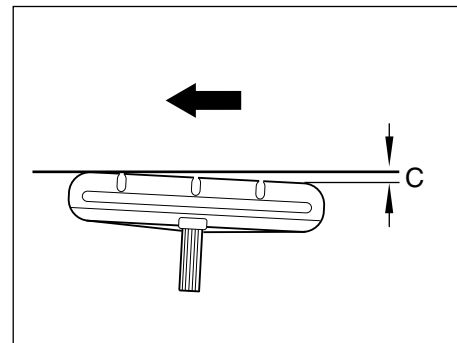

(C) = 0.5 mm

- The brake shoes must be adjusted to leave a gap of about 0.5 mm to the wheel rim to the rear in the direction of rotation.
- Tighten the nuts when the brake linings are correctly adjusted.
- Attach the brake cable.

Disassembling and assembling the brake cable

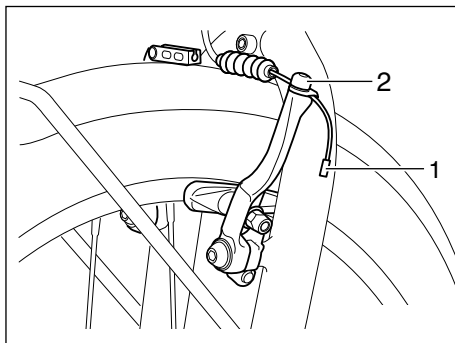

Disassembling

- Detach brake cable.
- Remove the protective cap (1) using a pliers.
- Unscrew screw (2) by a few turns and remove the sheated cable.

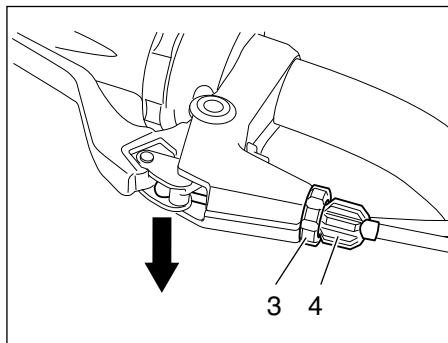

- Set the counter nut (3) and setting screw (4) such that the slot coincides with the opening on the brake lever.
- Remove the brake cable from the brake lever and pull it from the cable conduit.

Assembling

- Attach the new brake cable to the brake lever and drive it through the counter nut (3) and setting screw (4).
- Tighten the setting screw completely.

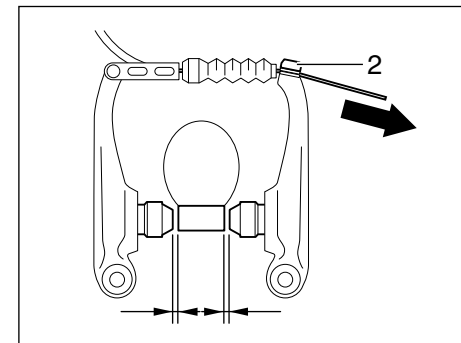

- Pull the brake cable through the cable conduit and drive it through the clamping bracket.
- Set the gap between the left and right brake shoe and the wheel rim to 2 mm and tighten the cable screw (2) (tightening moment 6-8 Nm).
- Clip a new protective cap on the end of the brake cable.
- Pull the brake lever about 10 times to the grip and verify the proper and correct operation of the brake.

Disassembling the front wheel

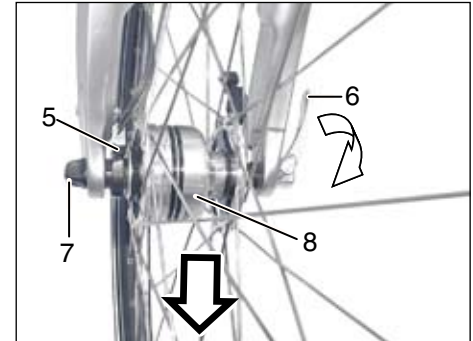
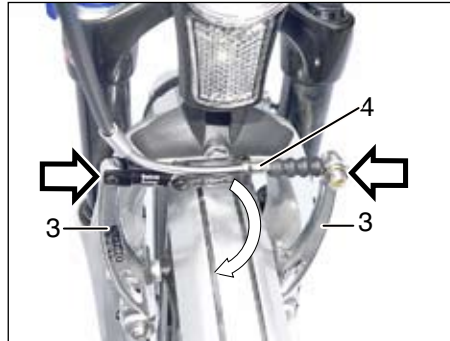

Disassembling

- Loosen the counter nut (1) on the hand brake lever and screw in the setting screw (2).
- Press both brake arms (3) together and extract the brake cable guide (4) from the bracket.
- Remove the cable plug (5) from the dynamo.
- Open the quick release lever (6) and loosen the axle nut (7) by a few turns.
- Remove the front wheel (8) off the fork by pulling downward.

Assembling the front wheel

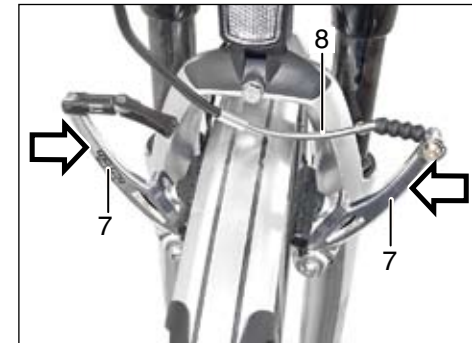
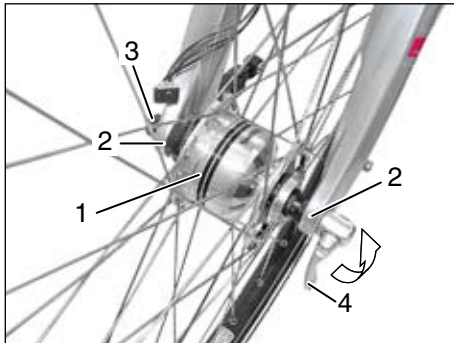

Assembling

- Seat the front wheel (1) in the front fork ends (2).
- Align the dynamo connector (5) for the cable plug (6) and connect it.
- Pre-tighten the axle nut (3) and close the quick release lever (4).
- **The lever must point to the rear and close against perceptible resistance.**

WARNING

If the quick release lever is not completely closed it can open by itself. This can cause heavy falls.

Moving the quick release lever must be so hard that it requires using the hand palm push. Only this guarantees that the tension is strong enough.

- Press both brake arms (7) together and attach the brake cable guide (8).
- Verify the operation of the brake.

Disassembling and assembling the rear wheel

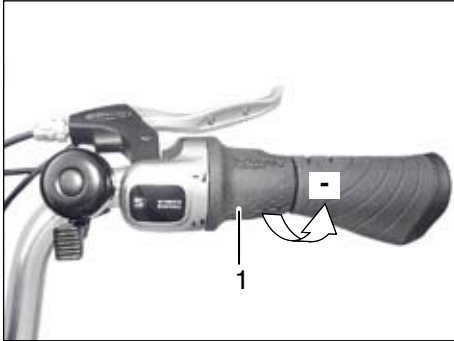

Disassembling

- Turn the gear shift handle grip (1) on the handlebar to shift to the first speed.
- Loosen the axle nuts (2 and 3) on both sides by means of a ring spanner wrench SW 15.

Disassembling and assembling the rear wheel

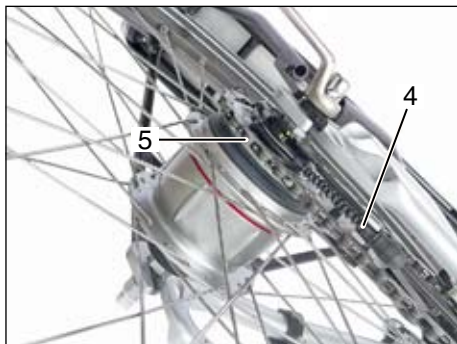

- Take the gear shift cable (4) off the shift lever.
- Take the chain (5) off the chain pinion and remove the wheel from the frame ends.

Assembling

- Drive the chain over the chain pinion and install the wheel in the frame end.
- Pre-tighten the axle nuts (2 and 3) by hand.
- Verify and adjust chain tension (see chain tension).
- The front and rear wheel must align exactly (stand on one line).
- Tighten the axle nuts.

Tightening moment for the axle nuts is about 40 Nm.

- Attach the gear shift cable (4).



NOTE

Adjust the gear shifting as described in the attached SHIMANO instructions.

8-speed hub gear

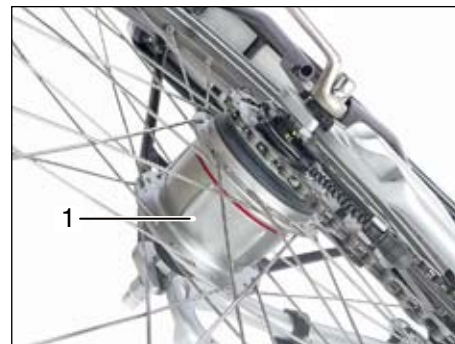

Care

- The 8-speed hub (1) is adequately lubricated.
- When needed service lubrication only by your daum electronic dealer.
- Do not spray water on the 8-speed hub when cleaning the wheel.
- If the lateral play of the rear wheel becomes too large, please have the bearings adjusted by your daum electronic dealer.



NOTE

Adjust the gear shifting as described in the attached SHIMANO instructions.

Dismounting and mounting the tyres

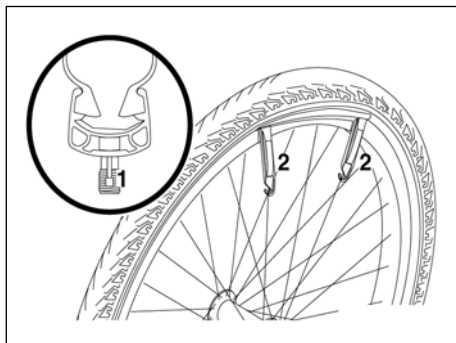

NOTE

In principle, we recommend that you always install a new inner tube.

You should use a plastic tyre lever for an easier removal of the tyre.

An accessory set with tyre levers and repair kit is available from your daum electronic dealer.

- Disassemble the tyre (see disassembling and assembling the front and/or rear wheel).
- Unscrew the dust cap on the valve, press the needle (pin) (1) inward and let the air out.

- Insert the longer end of the tyre lever (2) under the side of the tyre opposite to the valve and hook the short end under a spoke. Insert the second tyre lever under the tyre about 2 to 3 spokes away and hook it too. Release the tyre lever and remove the tyre cover from the rim edge with the hand.
- Press the tyre opposite to the valve into the rim well, then pull the tyre, in the region of the valve, with the hand over the edge of the rim and lift it off the rim over the whole circumference of the rim.
- Verify the inner side of the tyre to detect any damage or any foreign object (nails, etc.) that may have penetrated.
- Lay in the tube and inflate it slightly, otherwise there is a risk that it gets crushed.
- Then pull the tyre over the rim edge, starting opposite to the valve.
- Before fully inflating the tyre, move the tyre laterally to and fro. Make sure that distance between the circular marking on the tyre and the tyre edge is the same all around the rim.
- Assemble the wheel (see disassembling and assembling the front and/or rear wheel).



WARNING

Please be careful when inflating the tyre with an air compressor (e.g. at a service station). Because of the small volume of the tubes the max filling pressure is reached very quickly. The tyre could burst.

Check air pressure

Please make sure that tyre air pressure is always maintained. Non observance of the pressure leads to poor wheel grip and to early tyre wear.

Tyre air pressure front and rear:

Total weight	bar
up to 100 kg	4.0
125 kg	5.5

Lighting system



The headlight (1) must be tilted to the front in such a way, that the centre of the light cone 5 m away from the head light will drop to half the height at which it leaves the head light.

In practice this means that the road may be illuminated to a maximum of 10 m.



Switch positions (2) on the head light:

- OFF** Light OFF.
- ON** Light ON (dynamo enabled).
- AUTO** The light turns ON automatically in case of poor light conditions.



Head light and rear light with stand-light

The light system is equipped with an automatic standlight system. This position light system works after a ride with head light turned on. On parking the light remains on for about 4 minutes.



NOTE

The head light and rear light (3) are not equipped with replaceable incandescent bulbs (LED or diode light).

If the light is not working, check first whether a cable connection is broken. If that is not the case then the head light and/or the rear light must be replaced.

Checking the fuse of the rechargeable battery and of the charger



ATTENTION

When checking or replacing the fuses:

- the rechargeable battery must be switched OFF,
- the power plug of the charger must be unplugged.

Do never use a stronger fuse or repair the fuse. Incorrect or improper handling can damage the whole electrical system!

If the fuse blows up without an apparent reason, please consult your daum electronic dealer.



NOTE

Use the following fuses for replacement:

Rechargeable battery (3) F 30A L 250V

Rechargeable battery (2) 5A 250V

Charger (5) T 10A L 250V

Replacing the fuse

- Open the cover (1 or 2) on the rechargeable battery or (4) on the charger.
- When replacing the fuse make sure it is well seated. Loose fuses will blow up.



- Complete the installation in the opposite sequence.

	Comfort	Trekking D	Trekking H
Chassis			
Aluminium frame AL 6061, polished, high value painting	•	•	•
Frame size S/M	44 cm	44 cm	48 cm
Frame size L/XL	52 cm	52 cm	56 cm
Adjustable suspension fork SR Suntour	•	•	•
Drive			
Powerful 250 Watt central motor drive developed and manufactured by daum electronic in compliance with DIN EN 15194, Low-Noise Technology, with daum sensors for the detection of crank movements and pedalling force	•	•	•
Intelligent assistance mode pre-adjustable in 3 levels	•	•	•
Pushing assistance up to 6 km/h	•	•	•
Pedalling assistance 0 to 25 km/h	•	•	•
Autonomy range up to 80 km, depending on the assistance level, total weight, terrain, road conditions, tyre air pressure, wind conditions, etc.	•	•	•
Rechargeable battery			
Lithium-Ion technology, 9.5 Ah, 36 V	•	•	•
Usable life expectation: about 500 charging cycles, 3-4 years	•	•	•
External charger 115/230 Volt, 4 Amperes, charging time 0 to 100 % about 3 hours	•	•	•

	Comfort	Trekking D	Trekking H
Handlebar and control elements			
Curved aluminium touring handlebar, aluminium stem adjustable in height and tilt	•		
Straight aluminium trekking handlebar, aluminium stem adjustable in tilt		•	•
Ergonomic handlebar grips, free of toxic substances	•	•	•
Control unit conveniently located on the left side for the assistance mode +/-, pushing assistance, dashboard display (scan)	•	•	•
Twist grip shifter on the right side with gear indicator	•	•	•
Brake lever with safety motor cut-out on both sides	•	•	•
Dashboard with 9.4cm (3.7") grey scale display with backlight and brightness sensor	•	•	•
Gear shift			
Shimano Nexus 8-speed hub gear with free-wheel, total transmission ratio 307%, twist grip shifter and gear indicator	•	•	•
Brakes			
Mechanical V-brakes on the wheel rim with power modulator front and rear	•	•	•
Wheels			
Aluminium extruded rims 700c, stainless steel spokes 2mm	•	•	•
Tyres with puncture guard protection and reflective stripes, 42-622	•		
Tyres with puncture guard protection and reflective stripes 40-622		•	•
Plastic mudguards with edge protection and rear spoiler	•	•	•

	Comfort	Trekking D	Trekking H
Lighting system			
Shimano hub dynamo in the front wheel 6 Volt, minimal rolling resistance	•	•	•
LED head light B&M Lumotec Fly IQ senso plus, 40 Lux, with light sensor and automatic standlight	•	•	•
LED rear light B&M Toplight flat with automatic standlight	•	•	•
Miscellaneous			
High quality convenient gel / cold foam saddle, suspended aluminium saddle pillar	•	•	•
Stable aluminium carrier rack with aluminium battery compartment, elastic rubber straps to fix the luggage, possibility to attach extra pack bags, load capacity 25 kg	•	•	•
Anti-slip safety pedals	•	•	•
Aluminium side stand	•	•	•
Dimensions and weight			
Weight bike without rechargeable battery	ca. 22 kg	ca. 22 kg	ca. 22 kg
Weight of the rechargeable battery	ca. 3.6 kg	ca. 3.6 kg	ca. 3.6 kg
Seat height for frame size S/M	89-100 cm	89-100 cm	93-107 cm
Seat height for frame size L/XL	95-110 cm	95-110 cm	100-116 cm
Step-through depth	46 cm	-	-
Authorised total weight (rider + bike)	125 kg	125 kg	125 kg
Dimensions (L/W/H in cm)	100/55/123	100/55/123	100/55/123

	Dashboard classic	Dashboard premium
Close control unit on the handlebar		
Pushing assistance up to 6 km/h	•	•
Preselection of the intelligent assistance mode +/- (3 levels)	•	•
Preselection of the values displayed on the dashboard (scan)	•	•
Dashboard functions		
9.4cm (3.7") grey levels display with background illumination and brightness sensor	•	•
Card slot for SD card, integrated SD/SDHC card reader	•	•
Interference free digital heart rate receiver	•	•
Integrated buzzer	•	•
Recording of the heart rate, speed, distance, and trip time on the SD card	•	•
Incline adjusted pedalling assistance	•	•
Barometric height measurement		•
GSM module with GPS for enhanced documentation of biking tours, transmission of position data via SMS or Internet (SIM card required)		•
Theft protection per SMS notification (SIM card required)		•
Gear recommendation for optimal travel range	•	•
Software update via SD card	•	•

	Dashboard classic	Dashboard premium
Dashboard display values		
Assistance mode	•	•
Display of remaining battery charge	•	•
Speed	•	•
Average speed	•	•
Maximum speed	•	•
Daily distance	•	•
Total distance	•	•
Daily trip time	•	•
Total trip time	•	•
Clock	•	•
Date	•	•
Heart rate (requires chest belt)	•	•
Average heart rate (requires chest belt)	•	•
Temperature		•
Incline		•
Height above sea level		•
GPS coordinates		•

Warranty Conditions

daum electronic gmbh will provide the following services within the scope of its legal liability obligations, in case a defect should occur, through its authorised daum electronic dealer (retailer) to the customer:

1. daum electronic gmbh will correct, through the authorised daum electronic dealer (retailer), during a period of 24 months starting at the delivery of the bike to the customer, the defects that occur pertaining to material and production defects, by repairing or replacing the parts in question according to legal liability regulations. daum electronic gmbh may decline to accept the demanded repair or replacement of the defective part, if this is only possible at the expense of disproportionate costs. In this case daum electronic gmbh may correct the defect, through the authorised daum electronic dealer (retailer), through the other respective possibility of fulfilment. If both subsequent fulfilment methods can only be executed at the expense of disproportionate costs, daum electronic gmbh may through the authorised daum electronic dealer (retailer) decline to accept the fulfilment altogether. The customer will then only be entitled to the legal benefits.
2. The installation of replacement parts within the scope of a warranty repair will not extend the applicable warranty that started at the delivery of the bike to the customer.
3. Signs of wear due to normal utilisation are excluded from the warranty, as well as wear due to improper operation and improper utilisation. Oxidation and corrosion are caused by environmental influences and are also excluded from the warranty obligations.
4. The customer will forfeit his right to warranty claims in the cases of: manipulating the bike, modifying the drive and secondary transmission ratio, and by installing accessories and spare parts that are not authorised by daum electronic gmbh. The right to warranty claims will also be forfeited in the case of intervention in a workshop not authorised by daum electronic gmbh, as well as not respecting the prescribed maintenance intervals at an authorised daum electronic dealer.
5. When filing a warranty claim the customer must present the service booklet properly filled to the retailer.
6. The following table gives the customer a summary about the average limits concerning the respective wear parts:

Wear parts list

Wear parts	Wear limits
Tyres, inner tyre tubes, wheel rims	Depending on the driving style, the load and the tyre air pressure, the wear limit can be reached at 500 km or earlier.
Wheels, spokes, hubs	Depending on the driving style, the load and the tyre air pressure, the wear limit can be reached at 1000 km or earlier. Oxidation is due to a maintenance deficiency!
Suspension fork	To be controlled at every maintenance period.
Lighting, electric system, control electronic	Depending on the road characteristics / roughness, the life expectancy can be reduced, the limit can already be reached at 500 km.
Brake linings	Depending on the driving style and load these can be worn out at 500 km.
Seal rings, sealing, O-rings	These must be replaced at every maintenance interval to ensure a flawless operation.
Shaft seal rings of the motor, transmission, fork and wheels	Depending on the road characteristics and care provided, these can be worn out from 500 km. Dirt contamination can reduce the life expectancy. To be controlled at every maintenance interval. Do not wash with the high pressure cleaner!
Wheel bearings, Steering bearings	Depending on the road characteristics and care provided, these can be worn out from 500 km. Dirt contamination of the wheel hubs can reduce the life expectancy. To be controlled at every maintenance interval. Do not wash with the high pressure cleaner!

Wear parts list

Wear parts	Wear limits
Cables, cable connections, switches	Depending on the care provided, wear is possible from 500 km. To be controlled at every maintenance interval.
Cleaning and lubrication of the chain	Every 500 km and after every wash.
Pinions, chain wheels, chain guides, chain sprockets	Depending on the road characteristics and care provided, wear is possible from 500 km. Do not wash with high pressure cleaner! Control at every maintenance interval.
Rechargeable batteries, fuses	Depending on the ambient temperature a failure can occur after the 6th month, earlier in the case of shorter trips.
Sheated cables, brake cables	Depending on the utilisation and care from the 6th month.
Self locking nuts, splint pins, glued screw connections, tab washers	At every maintenance interval or every time the nuts or locks are opened.
Gear shifting components	Depending on the driving style and load these can be worn out at 500 km.

Delivery list

Frame serial number:	
sold on:	
by:	
daum electronic dealer seal:	

EC Declaration of Conformity

We declare that the construction of the device

Product : Pedelec bicycle
Model : ergo_bike pedelec

classic, order No. :	9510844	9512848	9514844
	9510852	9512856	9514852
	9500844	9502848	9504844
	9500852	9502856	9504852
premium, order No. :	9511844	9513848	9515844
	9511852	9513856	9515852
	9501844	9503848	9505844
	9501852	9503856	9505852

complies with the following regulations:

- Directive No. 2004/108/EC of the European Parliament and of the Council of December 15, 2004
- Directive 2006/95/EC of the European Parliament and of the Council of December 12, 2006

Applied standards:

- EN 15194



daum electronic gmbh
Flugplatzstr. 100
D-90768 Fürth
Tel.: +49 (0) 911/9 75 36-0
Fax.: +49 (0) 911/9 75 36-97



Fürth, on July 01, 2009



In order to protect your property we recommend you fill this card thoroughly.

Keep this card in your wallet. Should the bike be stolen, this card will help you provide the police with the required information to significantly help recover your bike.

Please do not forget to always lock the bike when you park it (hook the cable or U-lock to a fixed object).

Bike ID card

Type of the bike: Electric bike
Make of the bike: **daum electronic ergo_bike pedelec**
Model:
Serial-No.:
Frame colour:
Tyre:
Particular marking:
.....



Store in a safe place

